

- ⓓ **Montageanleitung**
- ⓖⓑ **Assembly instructions**
- ⓕ **Instructions de montage**

## Premium Carport 5,62 x 3,09 m

Produkt Art.-Nr. 4296203 - 4296218  
4296303 - 4296318



- Observe the local building regulations and the snow load zones in your region.
- Before the assembly sort the parts and check the contents list according to the assembly instructions.
- At least 2 persons are required to assemble the carport kit.
- Follow the instructions and installation steps in the assembly instructions.
- The Twin-Wall Sheets do not walk on transverse running boards (at least 2 rafters).
- Point loads must be avoided absolutely
- Regularly remove snow from the roof
- Snow load 100 kg/m<sup>2</sup>lt makes sense to install a snow guard above the carport.
- Keep the gutter free of leaves, dirt and snow.
- The carport kit must be installed on a flat, solid surface (for example dry concrete).  
**Foundation dimensions: length 40cm x width 40cm x depth 80cm**
- Clean the Twin-Wall Sheets with water and a mild detergent and do not use abrasives, acetone or solvents!
- Defective or bent posts or beams must be replaced immediately.

Colour and size deviations etc. within the usual tolerances reserved. Our recommendations do not release the customer from the obligation to check the product on his own responsibility. In case of doubt, please consult a specialist. Technical modifications reserved

**Intended use:**

The Premium Carport was developed and manufactured in accordance with EN 1090. It may only be used to roof a car parking space. Any use other than the intended use described here is considered improper use. The manufacturer is not liable for any damage or consequential damage resulting from improper, incorrect or inappropriate use.

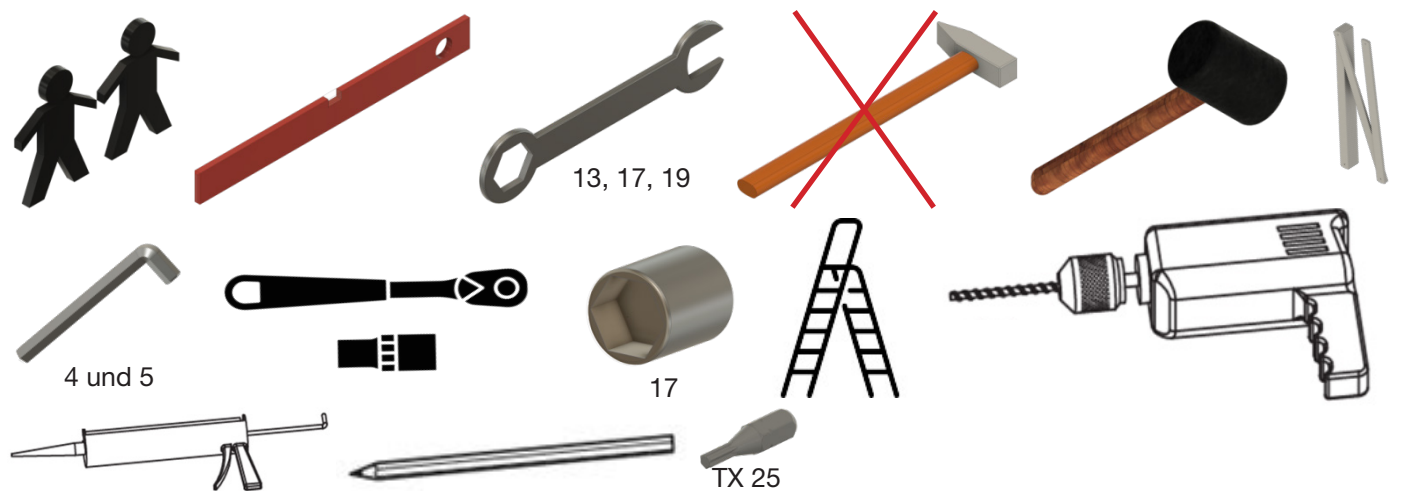

Nr.	Bezeichnung	Designation	désignation	Anzahl / Number / numéro
A	Hohlkammerplatte 980 x 5550 mm	Twinwall sheet 980 x 5550 mm	Plaque alvéolaire 980 x 5550 mm	3x
B	Pfosten 2010 mm / 2300 mm	Posts 2010 mm / 2300 mm	Poteaux 2010 mm / 2300 mm	2x / 2x
C	Vorderer Querträger / Pfette	Front cross beam / purlin	Poutre avant / panne	2x
D	Sparren Mitte (teilvermontiert)	Rafter middle (partly pre-assembled)	Chevron médian (partiellement préassemblé)	2x
E	Sparren Rand links und rechts (teilvermontiert)	Rafter Edge left and right (partly pre-assembled)	Chevron latéral droit et gauche (partiellement préassemblé)	2x
F	Querstrebe 30x30x948 mm	Cross brace 30x30x948 mm	Traverse 30x30x948 mm	6x
G	U-Profil für Hohlkammerplatten	U-Profil for Twinwall sheets	Profilé de fermeture pour plaque alvéolaire	6x
H	Alu Deckel	Alu Cap	Recouvrement alu entre plaques	4x
I	Deckel Vorderer Querträger / Pfette	Cap of front cross beam / purlin	Fermeture de la poutre avant / panne	4x
J	Deckel Regenrinne	Cap rain gutter	Fermeture latérale de gouttière	4x
K	Lagerprofil	Storage profil		8x
L	Regenrinne	Rain gutter	Gouttière	2x
M	Regenablauf	Rain drainage	Ecoulement d'eau pluviale	1x
Z.1	4295896 – Abdeckkappe SW 19	4295896 – Cover cap SW 19	Cache-écrou Cover cap SW 19	4x
Z.5	9210480 – 4,8x25 ISO 14585 A2 TX	9210480 – 4,8x25 ISO 14585 A2 TX	9210480 – 4,8x25 ISO 14585 A2 TX	32x
Z.6	9210481 – M12 DIN 127 B VZ	9210481 – M12 DIN 127 B VZ	9210481 – M12 DIN 127 B VZ	8x
Z.7	9210482 – Mutter M12 DIN 934 VZ	9210482 – Mother M12 DIN 934 VZ	9210482 – Ecrou M12 DIN 934 VZ	8x
Z.8	9210483 – M12x140 DIN 931 8.8	9210483 – M12x140 DIN 931 8.8	9210483 – M12x140 DIN 931 8.8	4x
Z.9	9210484 – M12x200 DIN 931 8.8	9210484 – M12x200 DIN 931 8.8	9210484 – M12x200 DIN 931 8.8	4x
Z.10	9210485 – M6 DIN 439	9210485 – M6 DIN 439	9210485 – M6 DIN 439	32x
Z.11	9210486 – M6x10 ISO 7380-2 10.9	9210486 – M6x10 ISO 7380-2 10.9	9210486 – M6x10 ISO 7380-2 10.9	32x
Z.12	9210831 - M12x80 DIN 931	9210831 - M12x80 DIN 931	9210831 - M12x80 DIN 931	8x
Z.14	9210495 – M8x25 ISO 7380-2 10.9	9210495 – M8x25 ISO 7380-2 10.9	9210495 – M8x25 ISO 7380-2 10.9	16x
Z.15	Aufnahme für Querträger	Holder for cross beam	Support pour poutre transversale	12x
Z.16	M8 DIN 1661 A2	M8 DIN 1661 A2	M8 DIN 1661 A2	16x
Z.17	Kantenverschlußband mit Membrane	Edge closing tape with membrane	Adhésif de fermeture avec membrane	1x

Nr.	Bezeichnung	Designation	désignation	Anzahl / Number / numéro
Z.18	Kantenverschlußband ohne Membrane (optional)	Edge closing tape without membrane (optional)	Adhésif de fermeture sans membrane (option)	1x
Z.19	Edelstahlschraube 6,3x32 inkl. Membrandichtung	Stainless steel screw 6,3x32 incl. membrane seal	Vis inox 6,3x32 avec joint	44x
Z.20	Bodenplatte	Floor slab	Dalle de plancher	4x
Z.21	9210488 M8 x 12 ISO 7380-2 10.9	9210488 M8 x 12 ISO 7380-2 10.9	9210488 M8 x 12 ISO 7380-2 10.9	8x
Z.22	Betonanker	Concrete anchors	Ancrages en béton	16x
Z.23				
Z.24	Montageschiene M8 für Strebenlagerung	Mounting rail M8 for strut mounting	Rail de montage M8 pour montage sur jambe de suspension	4x
Z.25	Strebenlagerung für Sparren	Strut support for beams	Support de jambe de force pour chevrons	4x
Z.26	Strebenlagerung für Pfosten	Strut support for posts	Support de jambes de force pour poteaux	4x
Z.27	Pfostenstrebe	Post strut	Attelle de poteau	4x

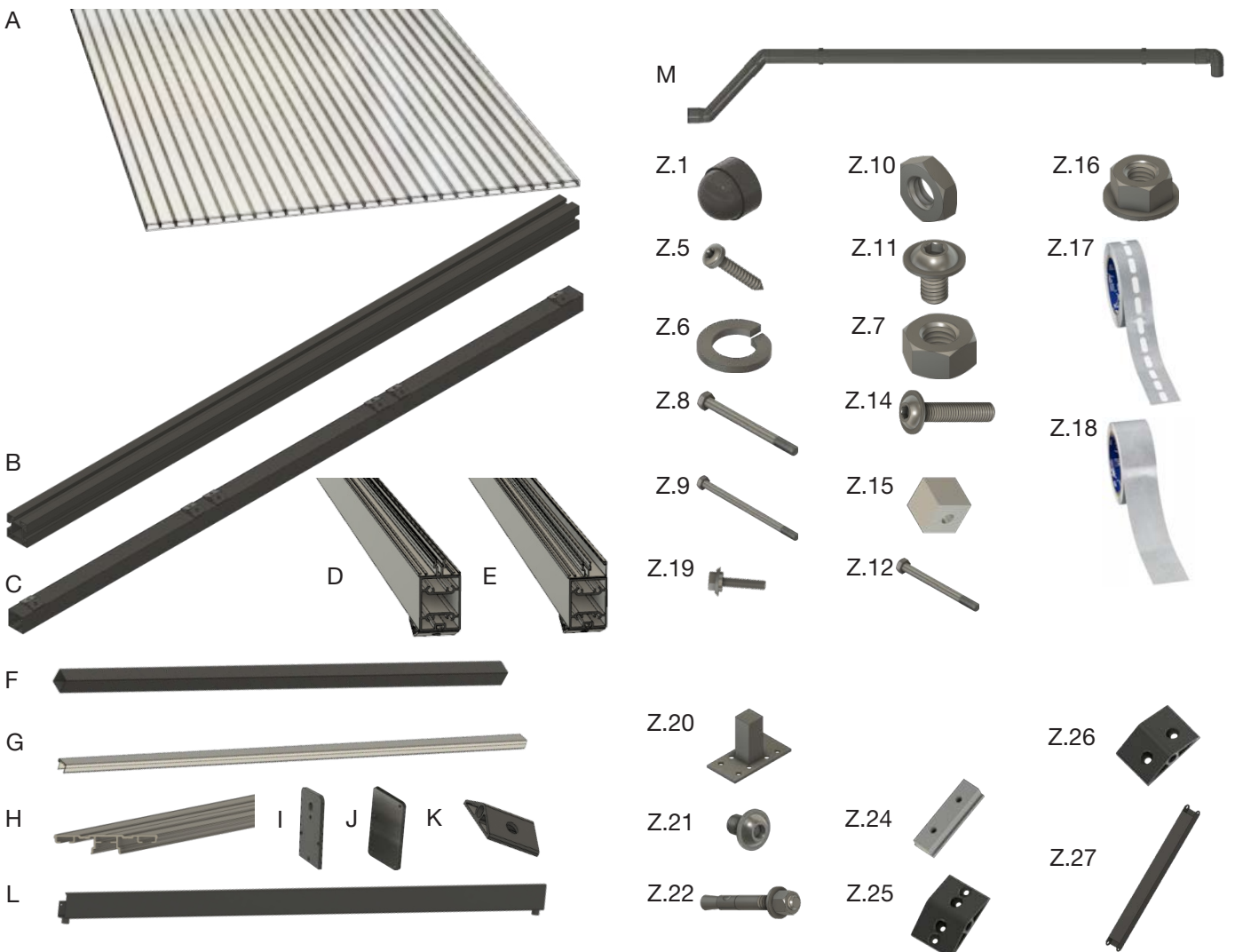

1.

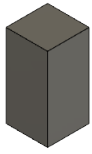

Fundamentmaße |  
Foundation dimensions |  
Dimensions des fondations

400 x 400 x 800 mm

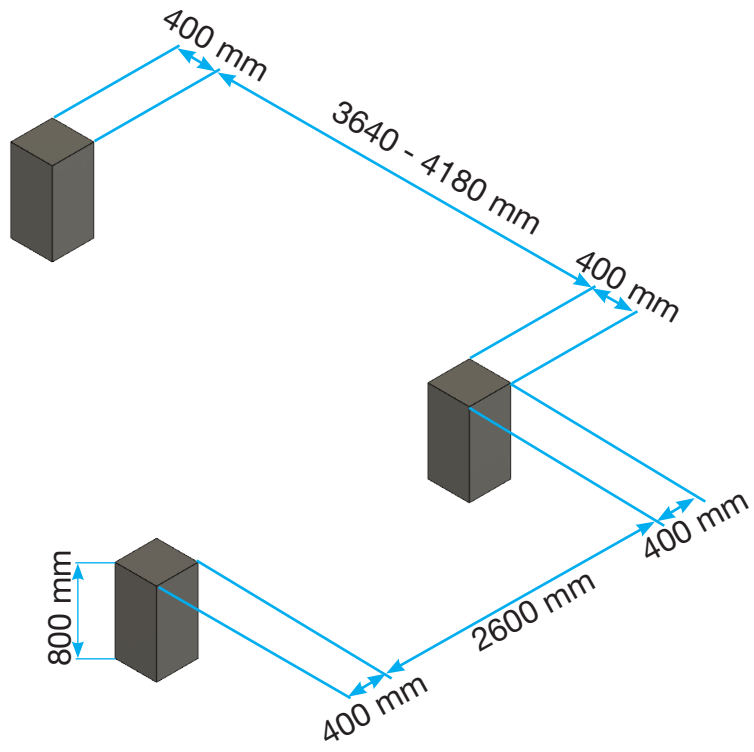

2.



B	2x	2300 mm
B	2x	2000 mm

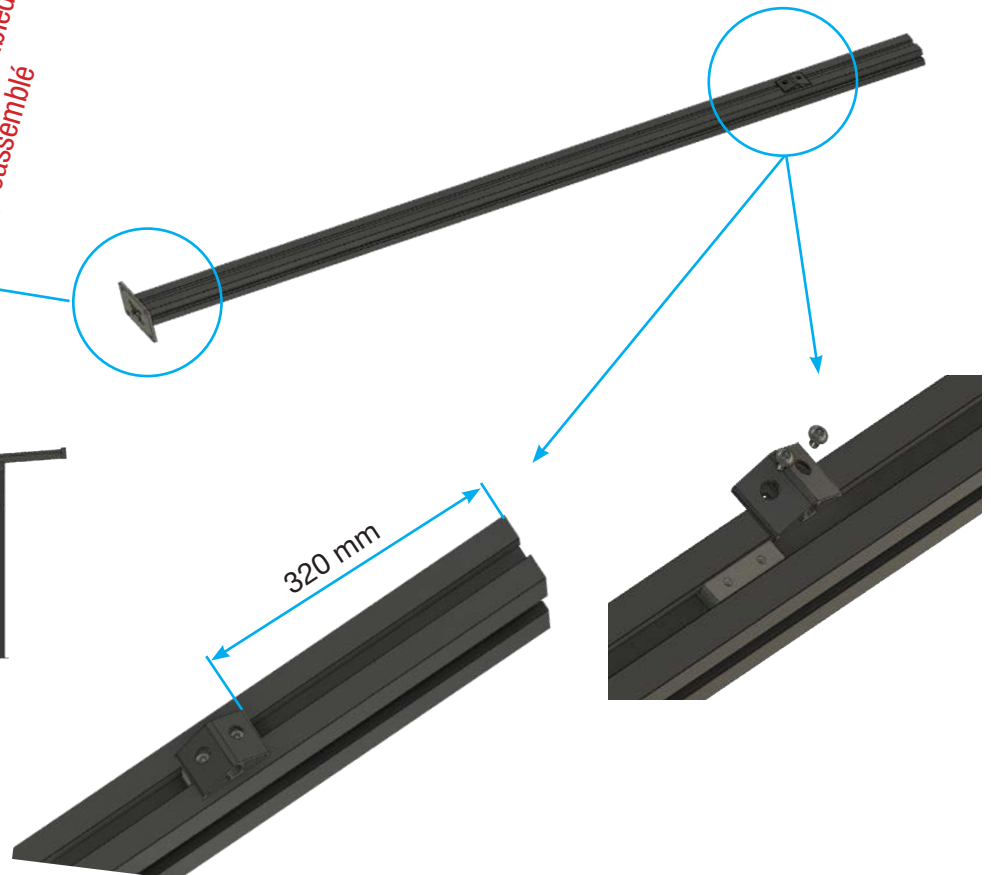
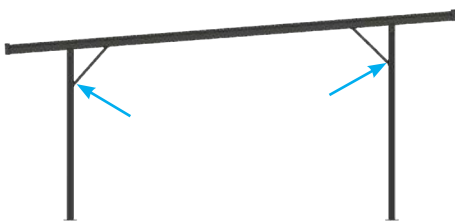
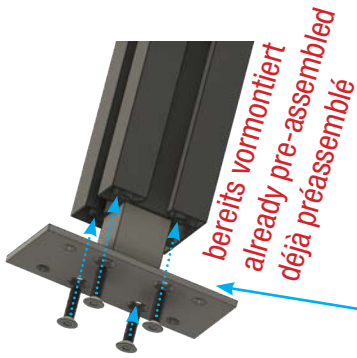

3.



C 2x



B 2x 2300 mm  
B 2x 2000 mm

Z.14 16x

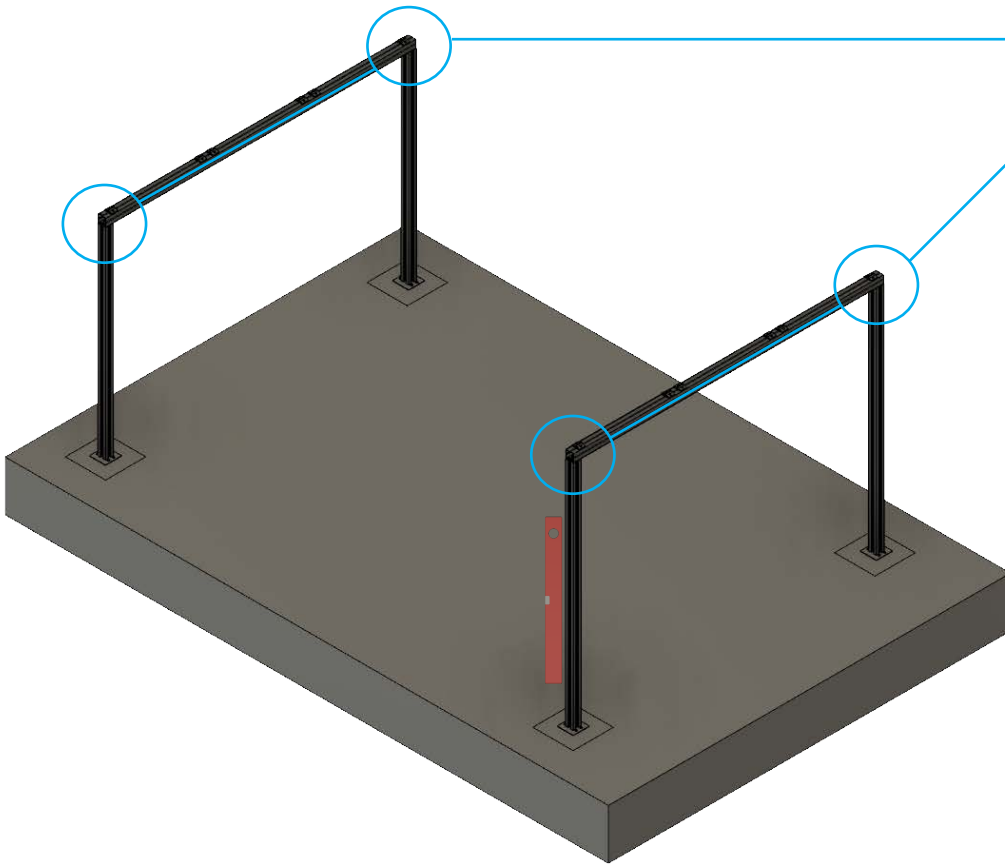
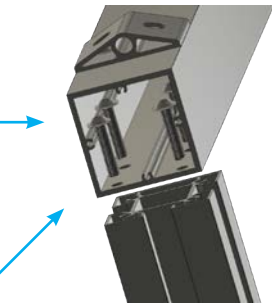

4.

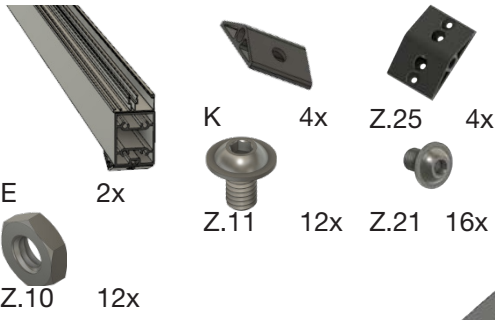

4a.

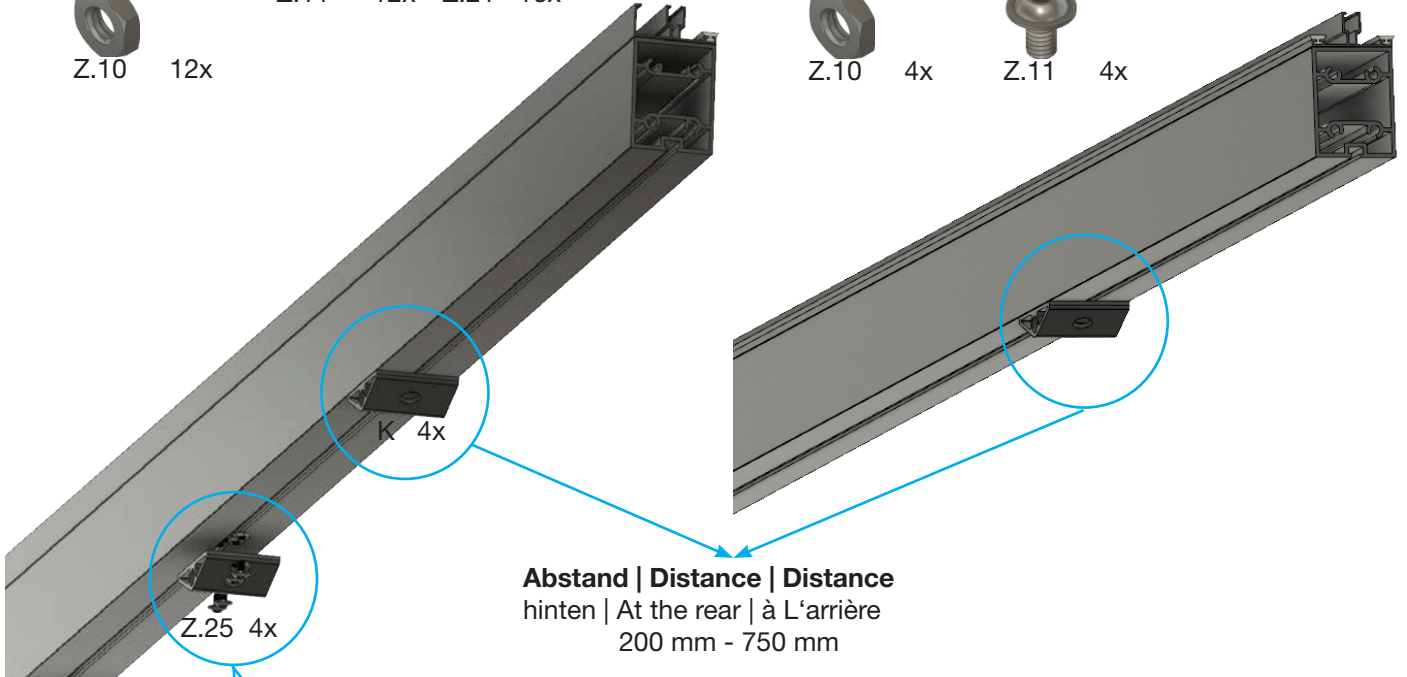
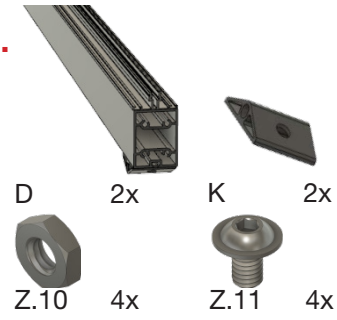

**Abstand | Distance | Distance**  
 hinten | At the rear | à L'arrière  
 200 mm - 750 mm

vorne | at the Front | à L'avant  
 100 mm - 750 mm

1x links | left | á gauche  
 1x rechts | right | correctes  
 2x mitte | middle | milieu

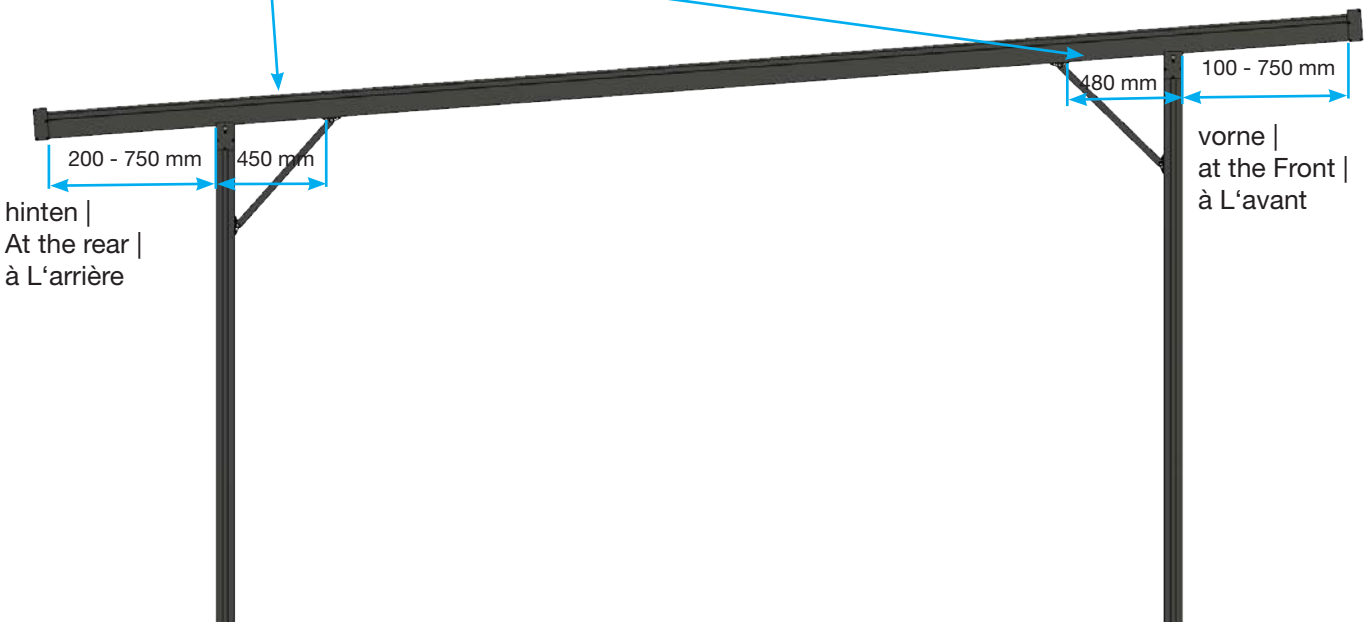

5.

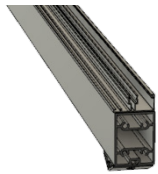

E 2x

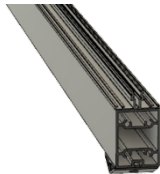

D 2x

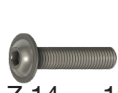

Z.14 12x



Z.15 12x

bereits vormontiert  
already pre-assembled  
déjà préassemblé

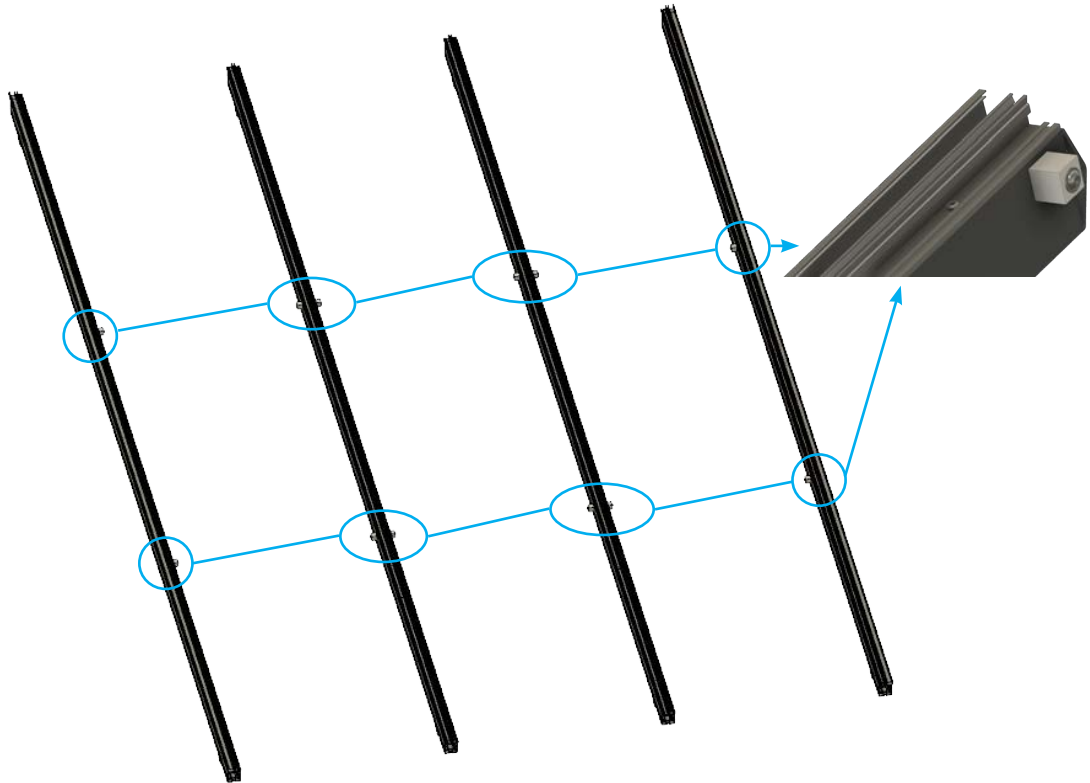

6.

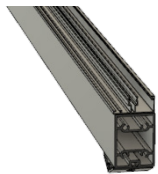

E 1x



Z.6 2x



Z.8 2x



Z.7 2x



I 2x

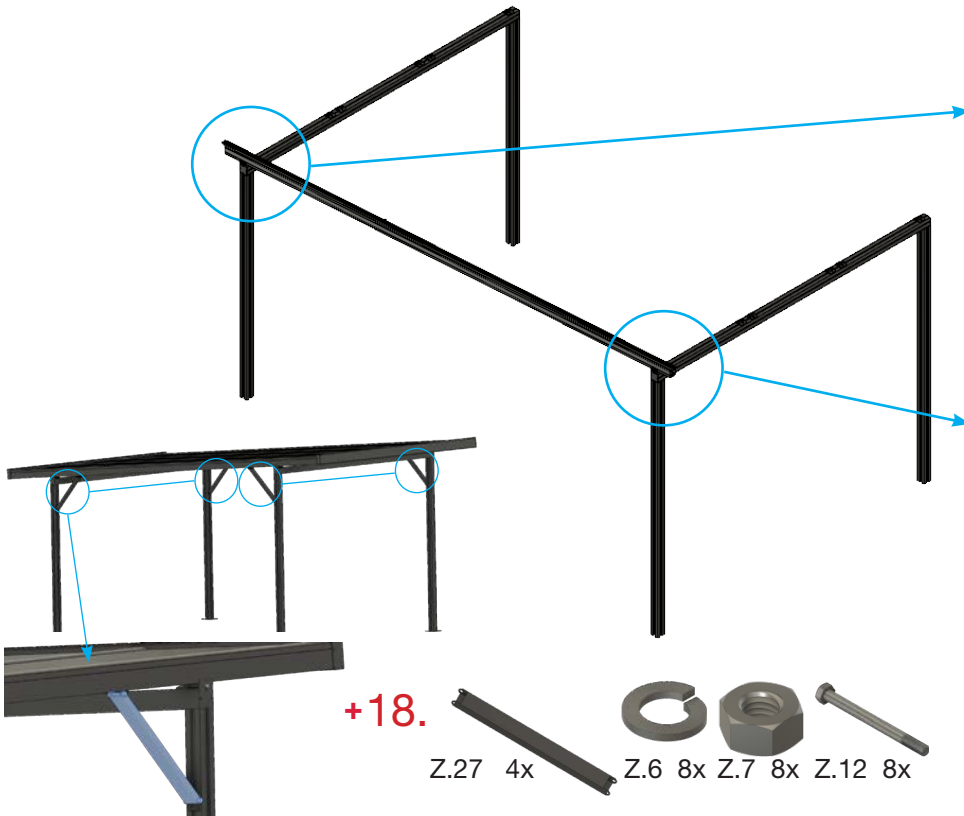
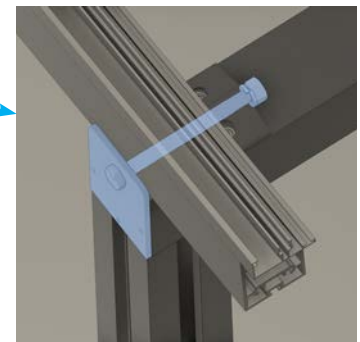
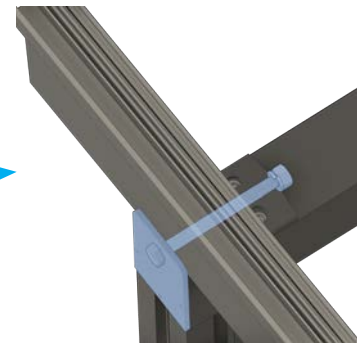

+18.



Z.27 4x



Z.6 8x



Z.7 8x



Z.12 8x



7.

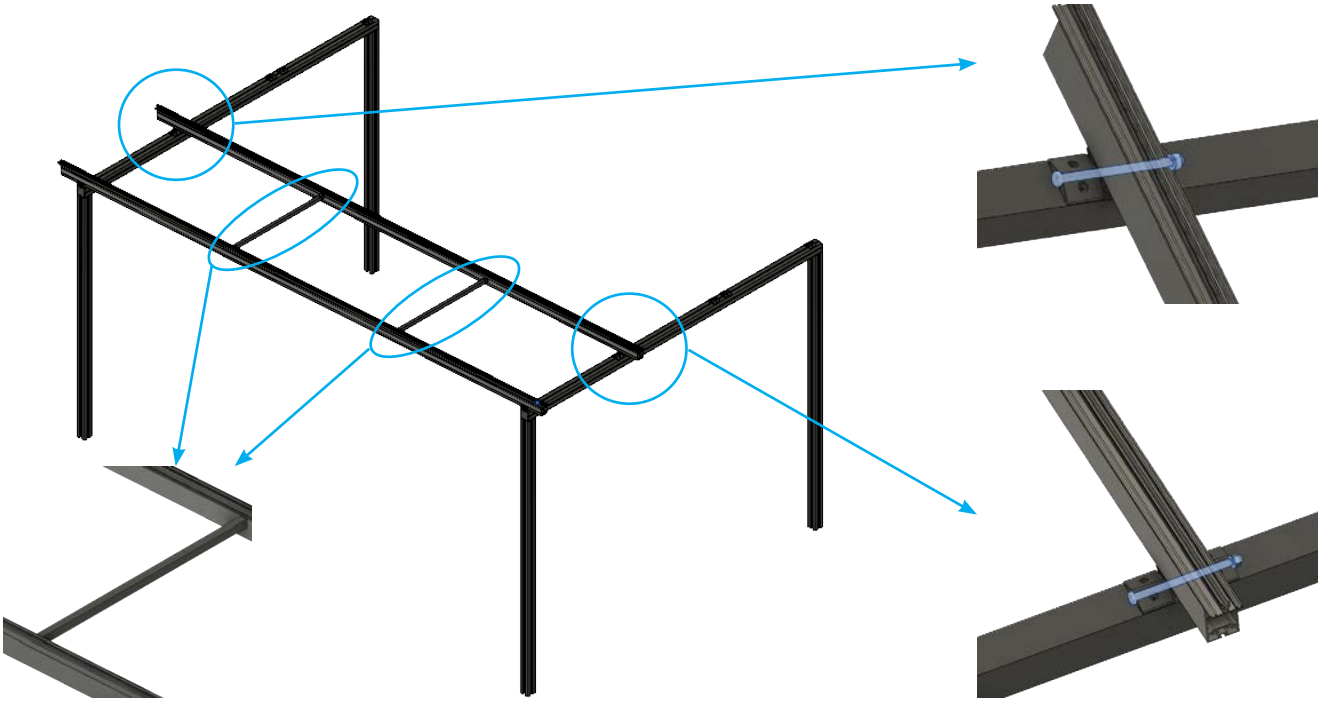
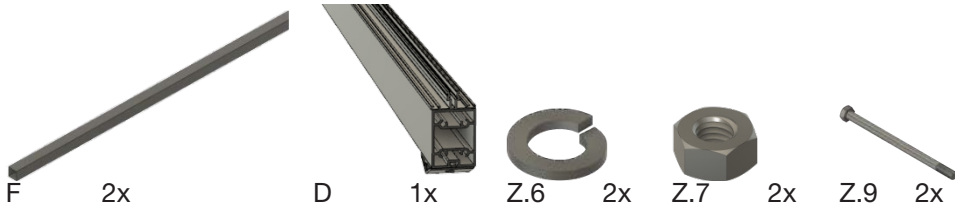

8.

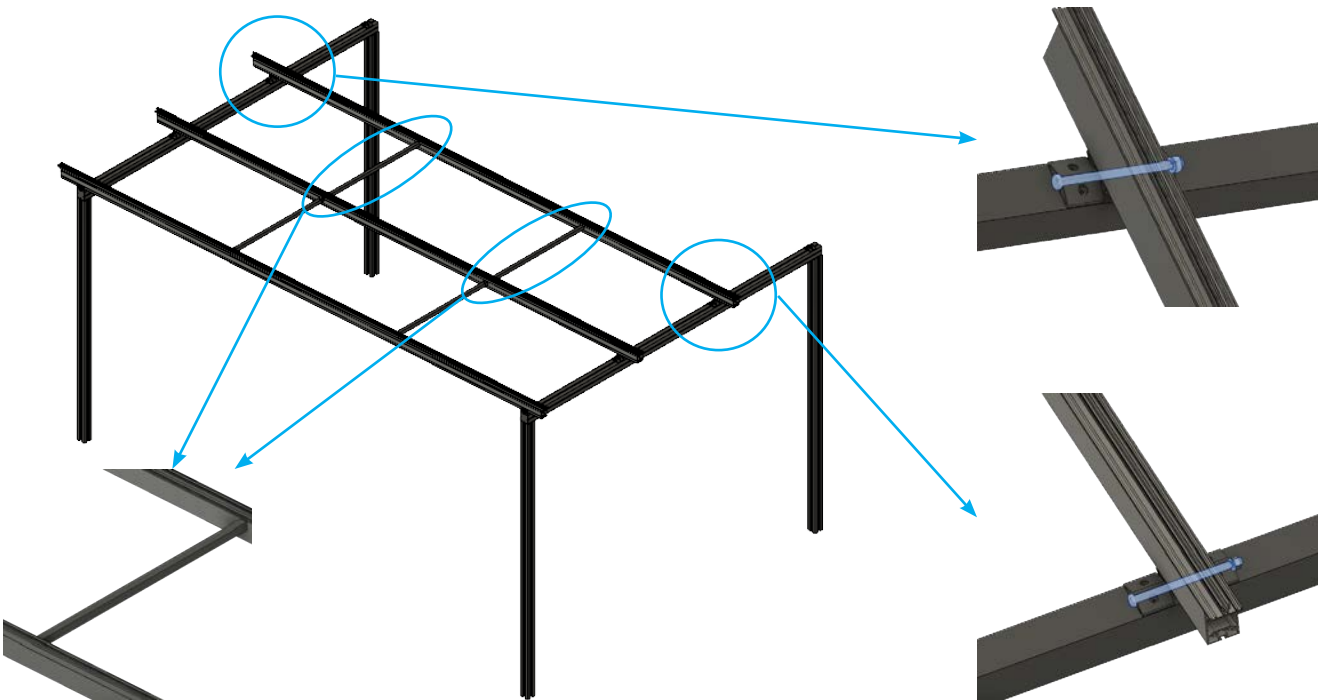
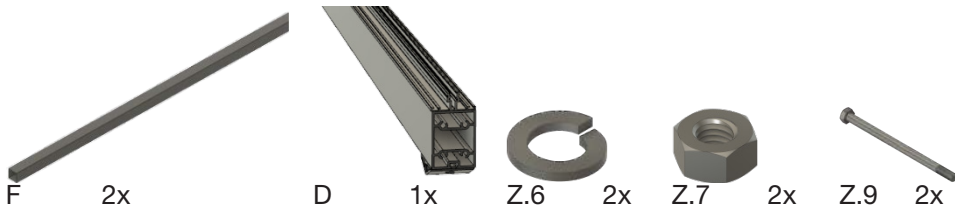

9.

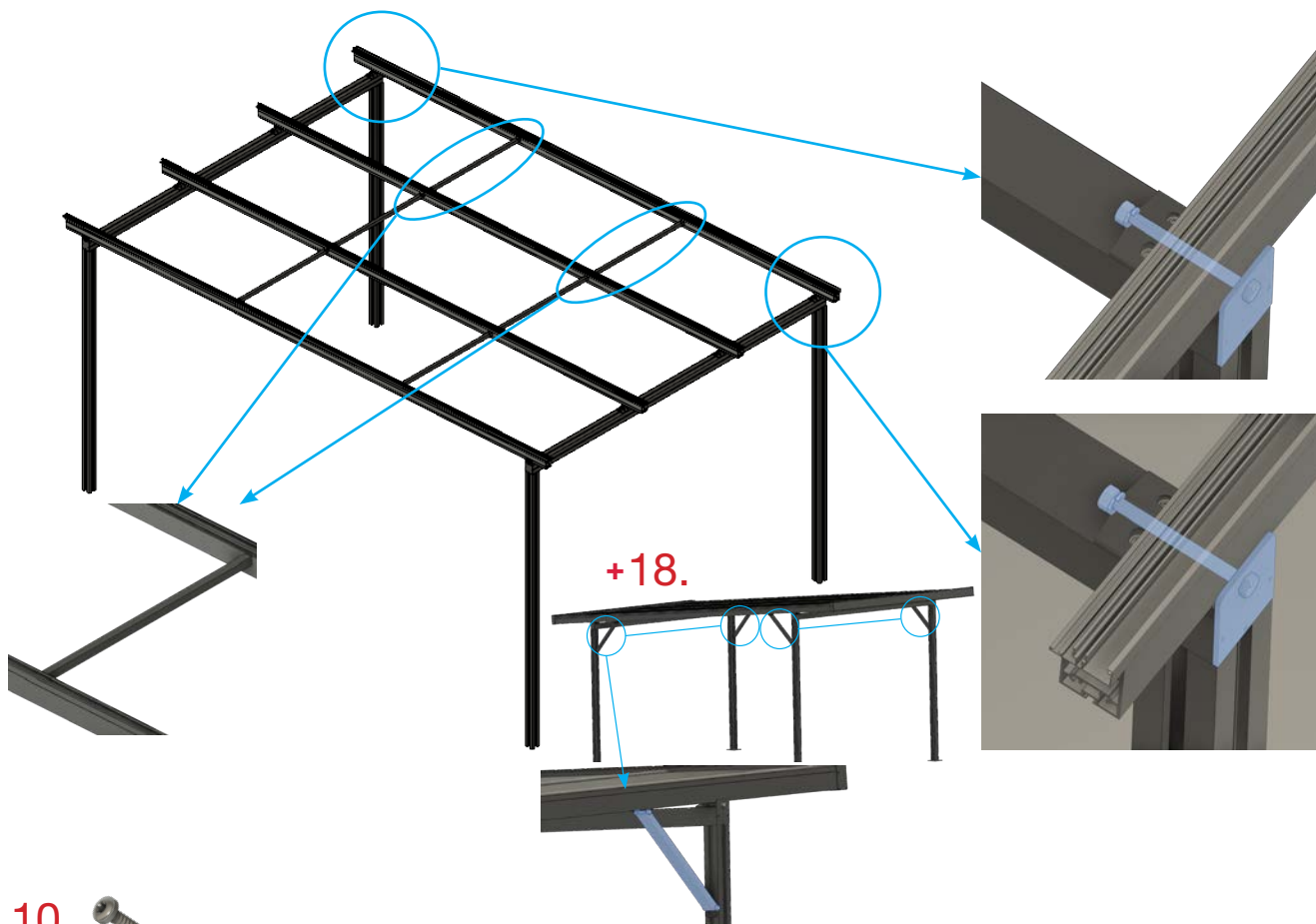
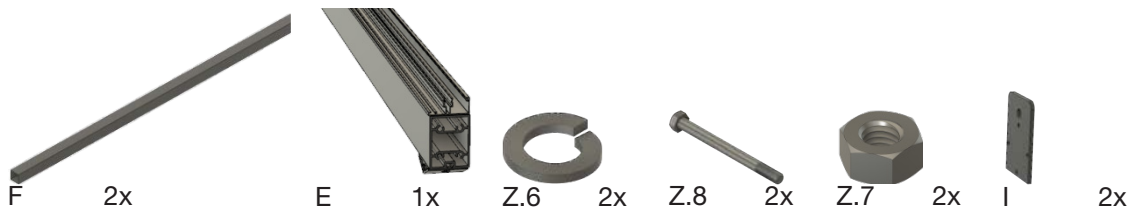

+18.

10.

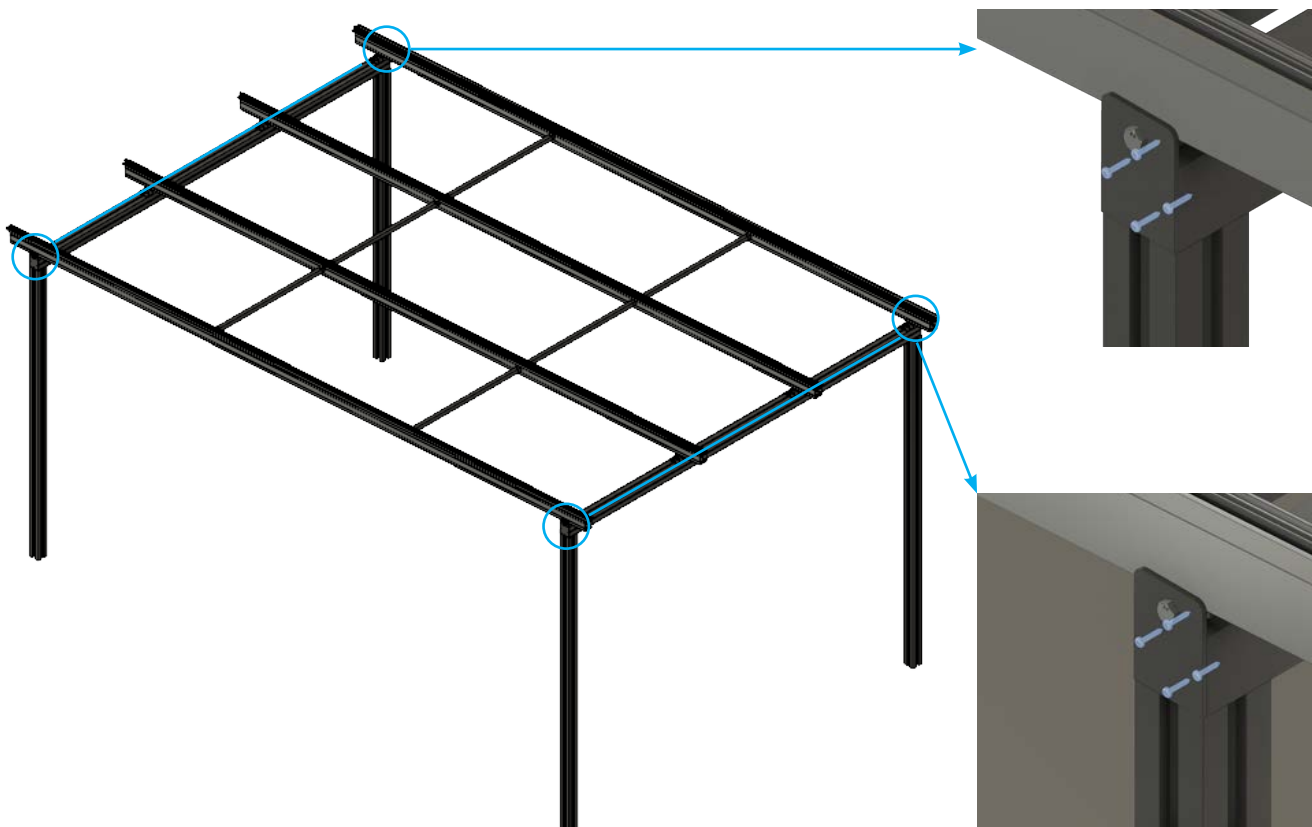

11.

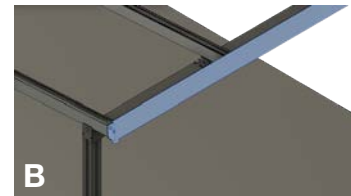
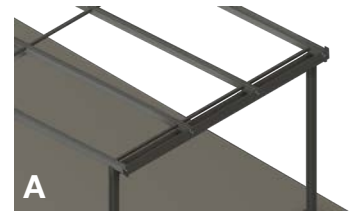
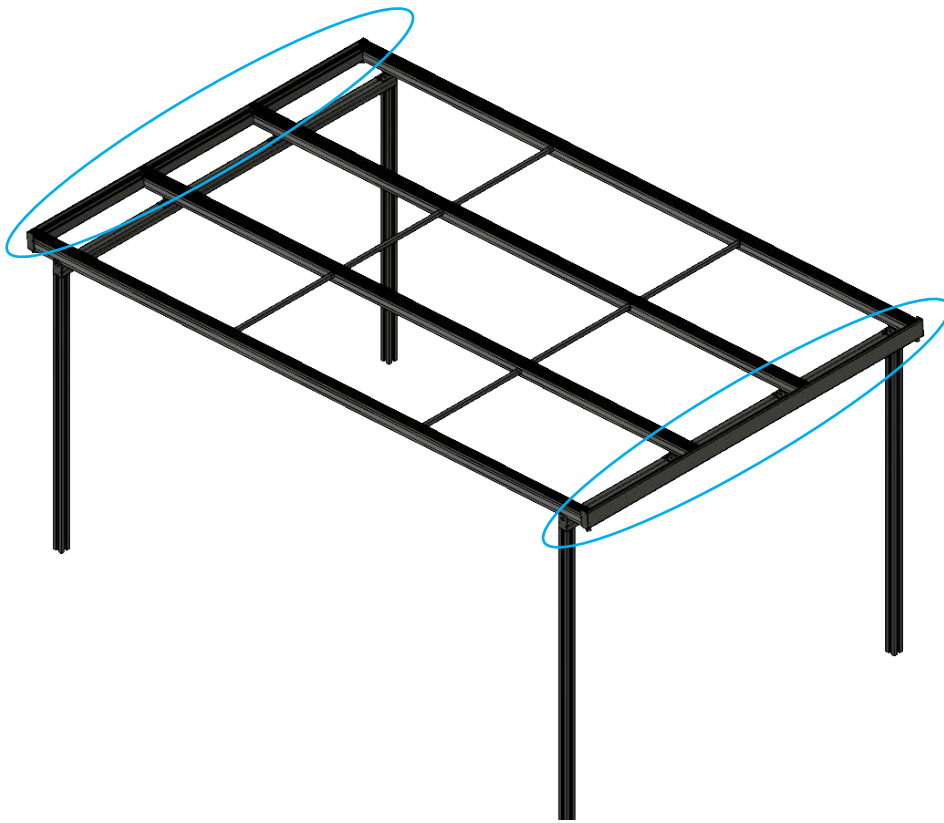

12.

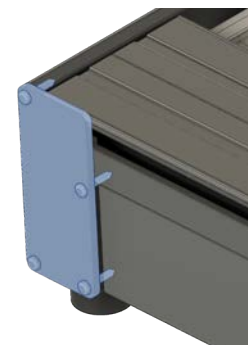
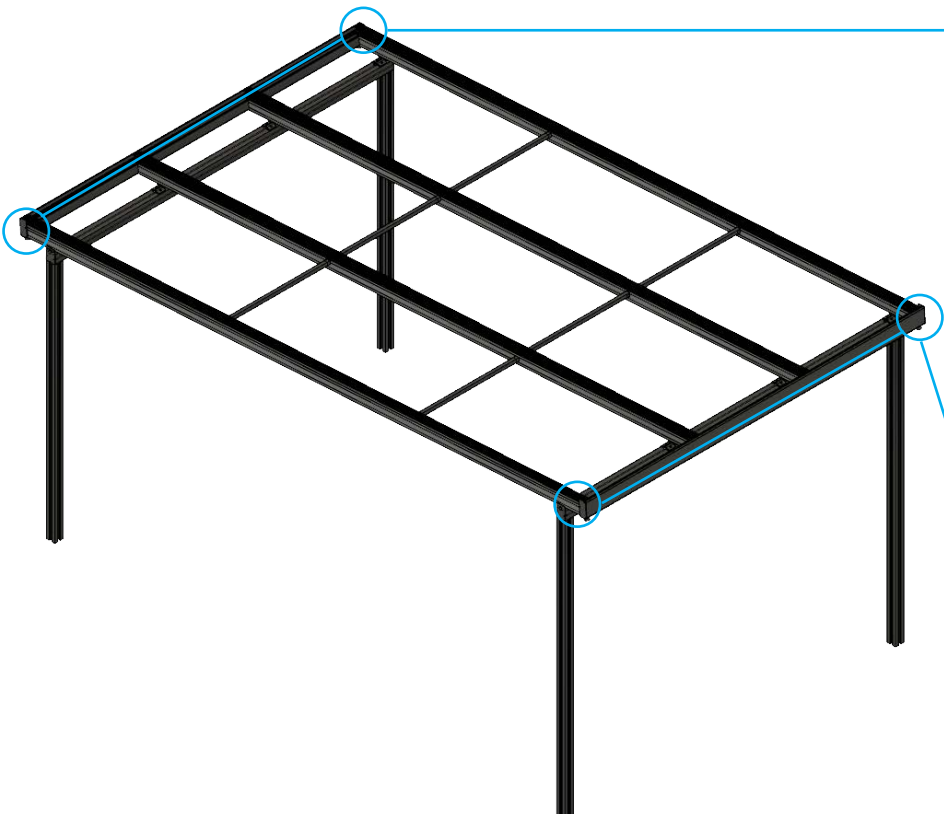

13.

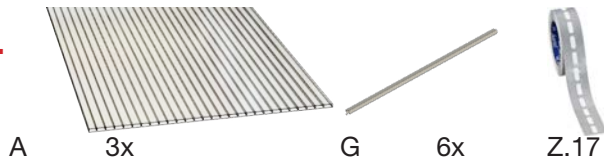

(Nur bei Acrylplatten im Lieferumfang enthalten / Only for acrylic sheets in the Included in delivery / Uniquement pour les plaques acryliques de la gamme Inclus dans la livraison)

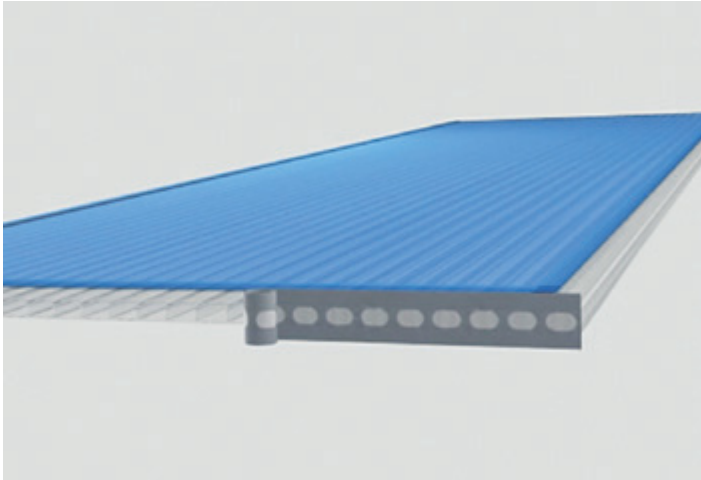

Zum Schutz vor eindringendem Staub und Schmutz kleben Sie die Stirnseiten der Platten mit dem Kantenverschlussband ab. Schlagen Sie dazu die Schutzfolie nur so weit wie nötig um.

To protect against dust and dirt, tape the front sides of the panels with the edge sealing tape. To do this, beat the protective film only as far as necessary.

Pour protéger contre la poussière et la saleté, collez les faces avant des panneaux avec la bande d'étanchéité de bord. Pour ce faire, battez le film protecteur que dans la mesure où c'est nécessaire.

#### Unsere Empfehlung!

Polycarbonatplatten: Traufe und First mit Membranband.  
Acrylplatten: Band mit Membran an der Traufe und Band ohne Membran am First.

#### Our recommendation!

Polycarbonate sheets: eaves and ridge with membrane tape.  
Acrylic panels: Band with membrane at the eaves and band without membrane at the ridge.

#### Notre recommandation !

Feuilles de polycarbonate : avant-toit et façade avec bande de membrane. Panneaux en acrylique : Bande avec membrane à l'avant-toit et bande sans membrane au faîte.

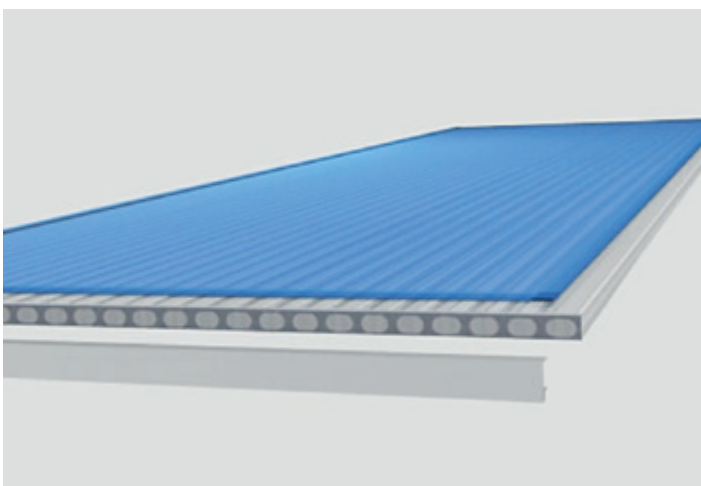

Stecken Sie nun die Alu-U-Abschlussprofile an den Stirnseiten auf. Achten Sie darauf, dass die gekennzeichnete Schutzfolie oben ist. UV-Schutz bei einseitig geschützten Platten! Die Tropfnase des Profils zeigt nach unten.

Now attach the aluminium U end profiles to the end faces. Make sure that the marked protective foil is on top. UV protection for panels protected on one side! The drip nose of the profile points downwards.

Fixez maintenant les profilés d'extrémité en aluminium sur les faces frontales. Veillez à ce que le film de protection marqué se trouve sur le dessus. Protection UV pour les panneaux protégés d'un seul côté ! Le nez d'égouttement du profilé est dirigé vers le bas.

14.

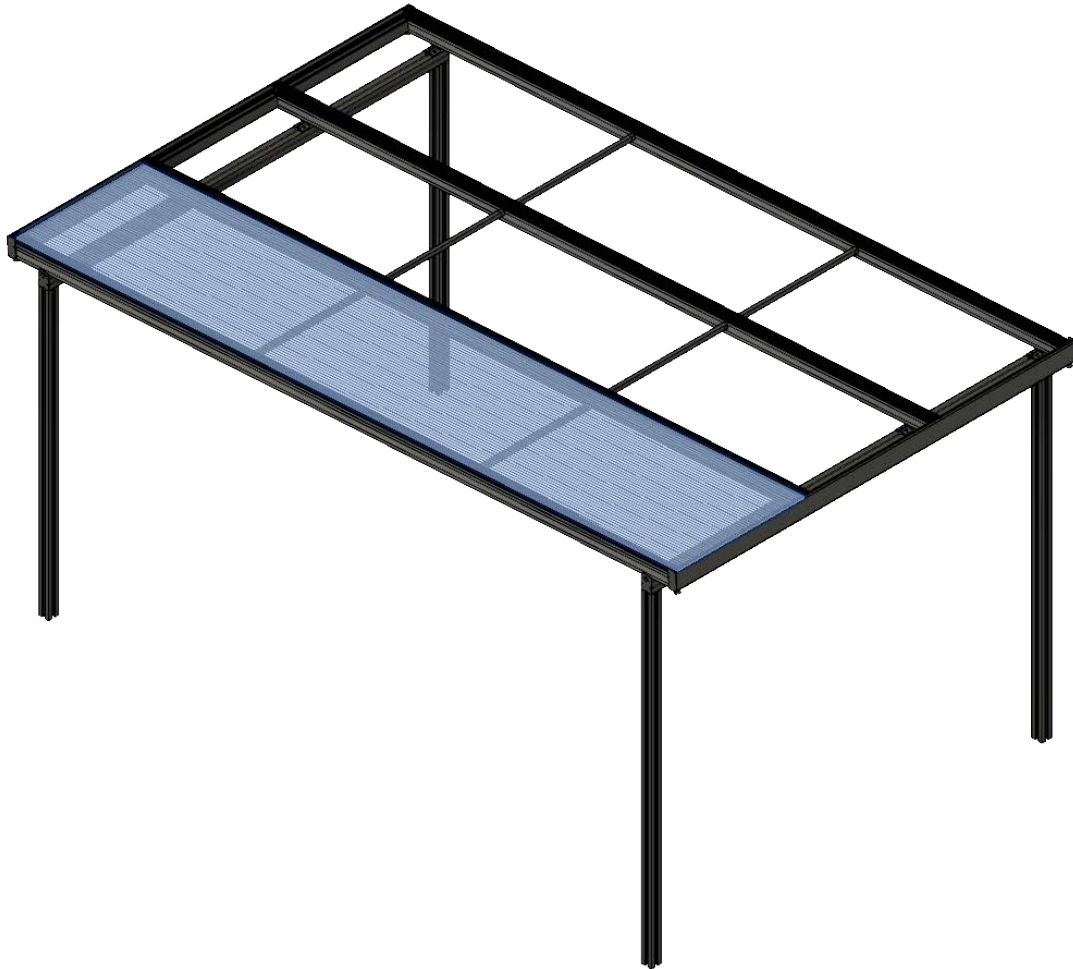
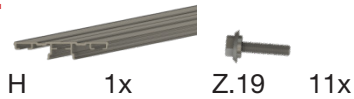

Legen Sie die erste Platte auf und richten Sie sie korrekt aus – beachten Sie auch hier die korrekte Ausrichtung der Schutzfolien. Profiloberteil alle 40 cm mittig vorbohren ( $\varnothing 7$  mm), die erste Bohrung erfolgt nach 6cm. Anschließend auflegen und mit dem Unterteil verschrauben.

Place the first panel on top and align it correctly - also make sure that the protective foils are aligned correctly. Pre-drill the upper part of the profile in the middle every 40 cm ( $\varnothing 7$  mm), the first hole is drilled after 6 cm. Then place it on the surface and screw it to the lower part.

Placez le premier panneau sur le dessus et alignez-le correctement - veillez également à ce que les films de protection soient correctement alignés. Pré-percer la partie supérieure du profilé au milieu tous les 40 cm ( $\varnothing 7$  mm), le premier trou est percé après 6 cm. Posez-le ensuite et vissez-le sur la partie inférieure.



15.

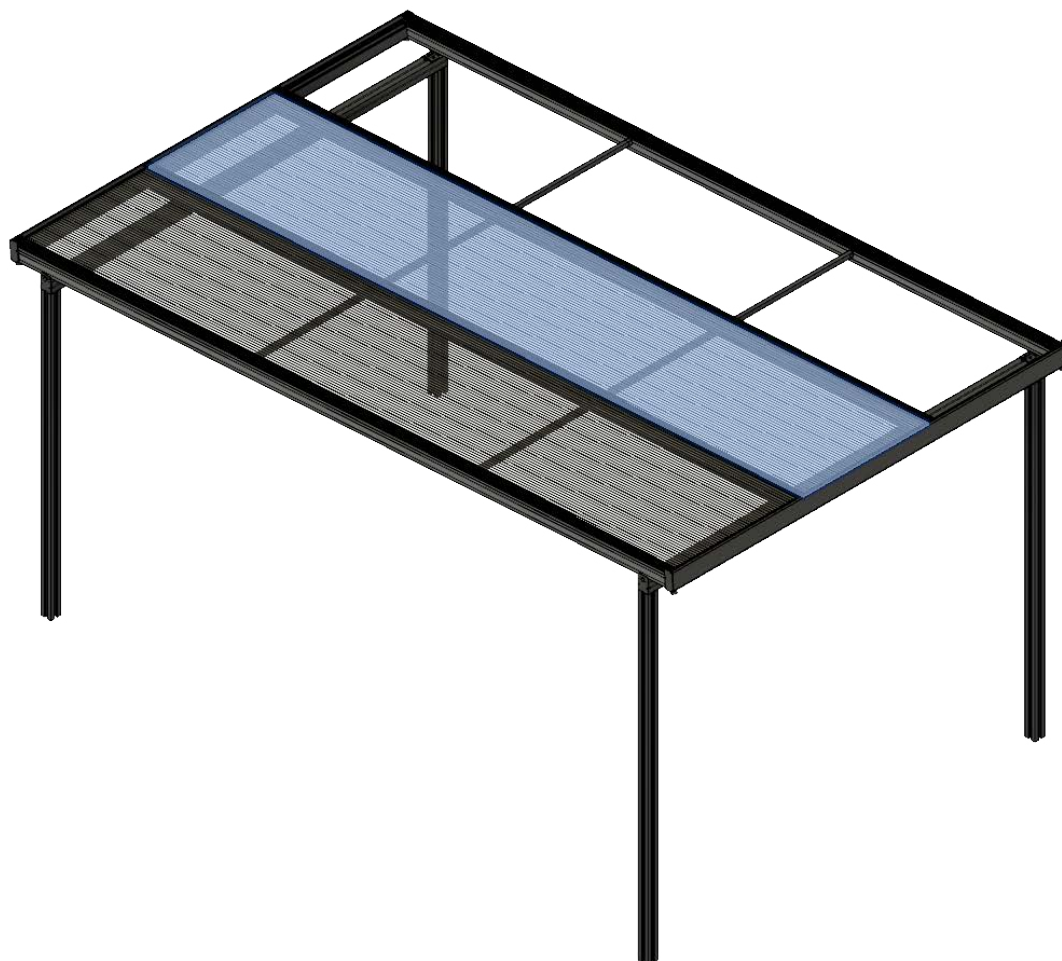
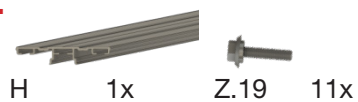

Montieren Sie in der gleichen Art und Weise die 2. Platte und verschrauben Sie diesen Deckel wie im Schritt 14. Ziehen Sie anschließend die Schutzfolien ab.

Assemble the 2nd plates in the same way and screw this cover together as in step 14. Then remove the protective films.

Monter les 2ème plaques de la même manière et visser ce couvercle ensemble comme à l'étape 14. Retirez ensuite les films de protection.

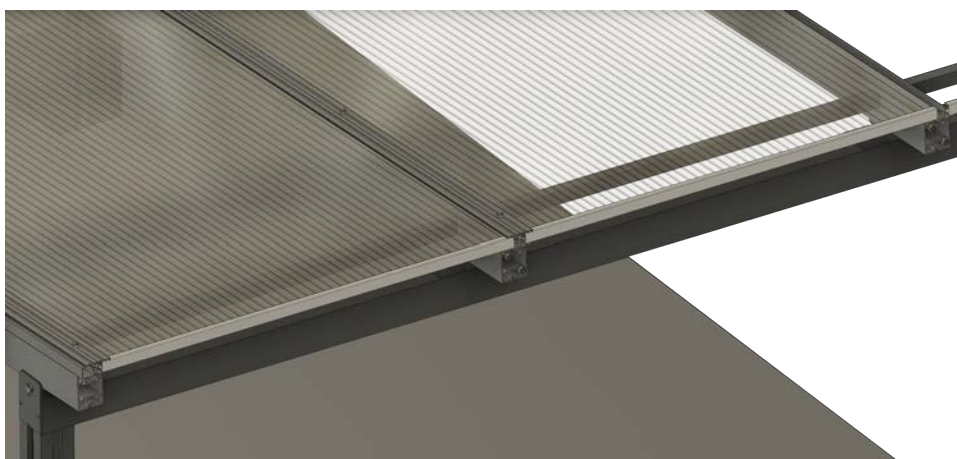

16.

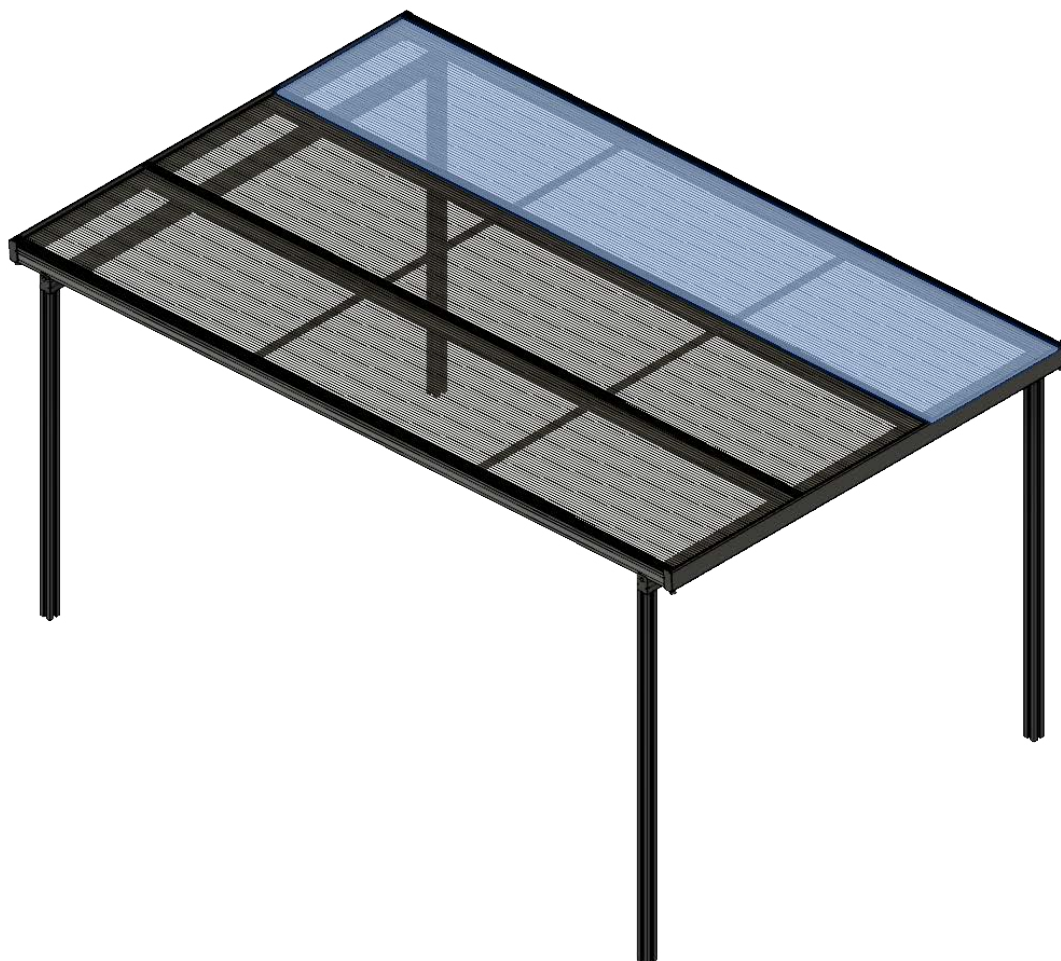
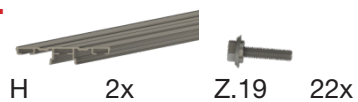

Montieren Sie in der gleichen Art und Weise die 3. Platte und verschrauben Sie diesen Deckel wie im Schritt 14. Ziehen Sie anschließend die Schutzfolien ab.

Assemble the 3rd plates in the same way and screw this cover together as in step 14. Then remove the protective films.

Monter les 3ème plaques de la même manière et visser ce couvercle ensemble comme à l'étape 14. Retirez ensuite les films de protection.



17.  Z.1 4x

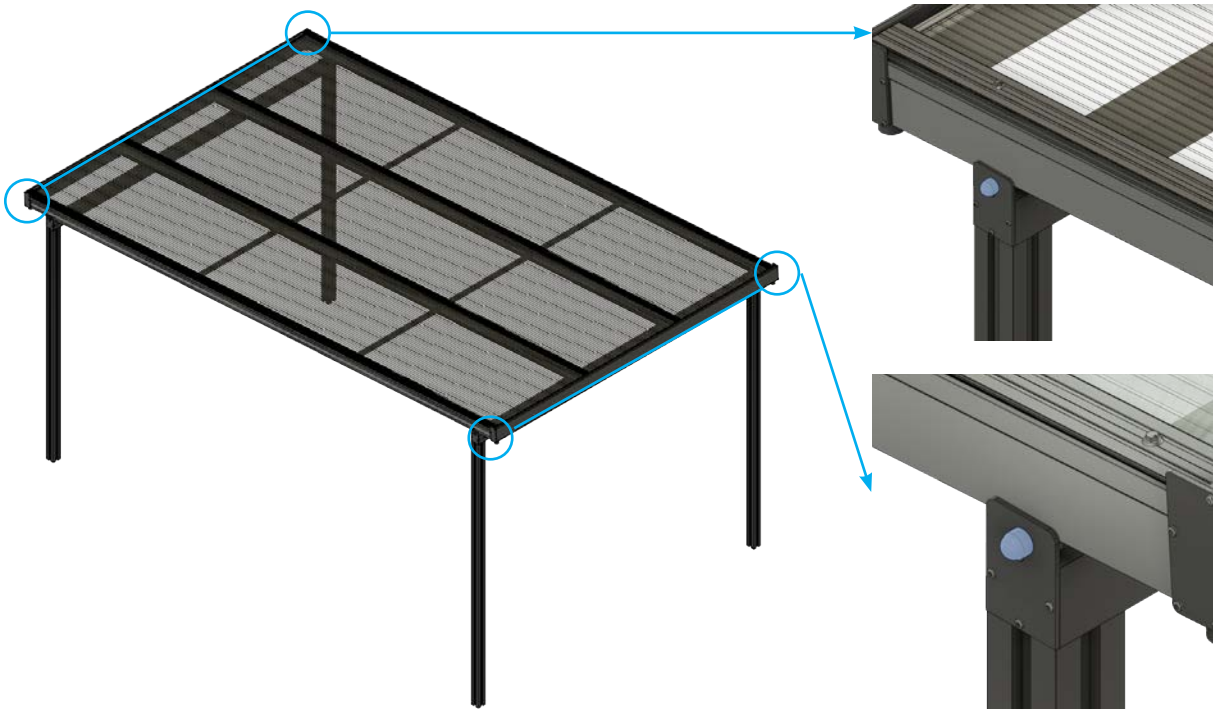

18.  Z.27 4x  Z.6 8x  Z.7 8x  Z.12 8x

Montage erfolgt bei Punkt 6 und 9.  
Assembly takes place at points 6 and 9.  
L'assemblage s'effectue aux points 6 et 9.

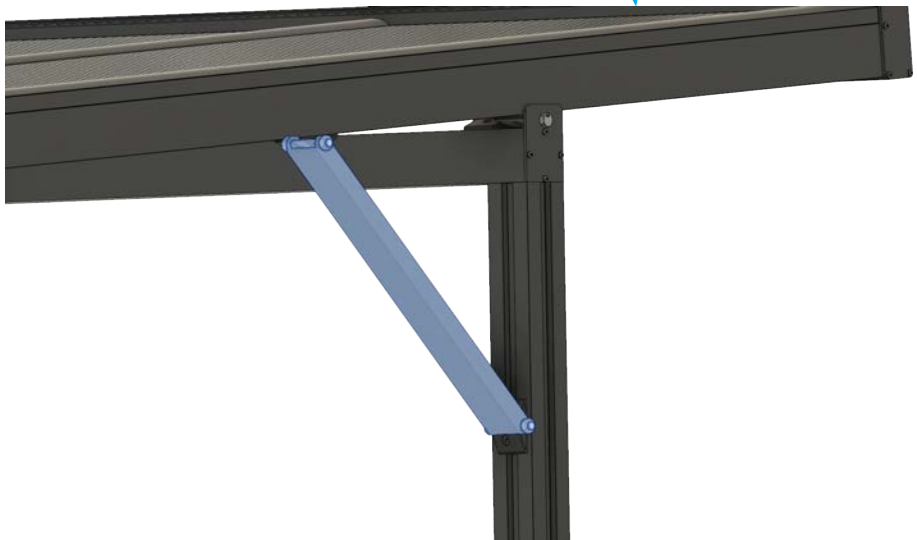
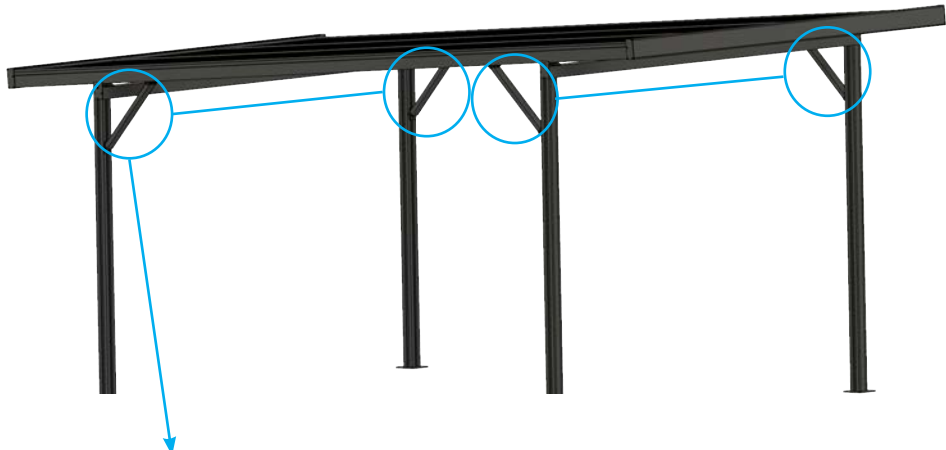



19.  Z.22 16x

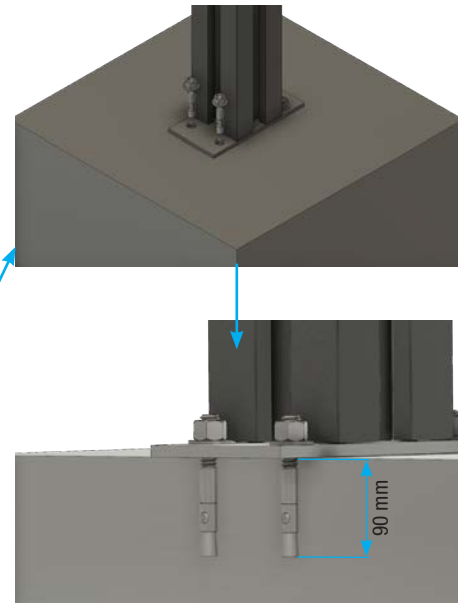
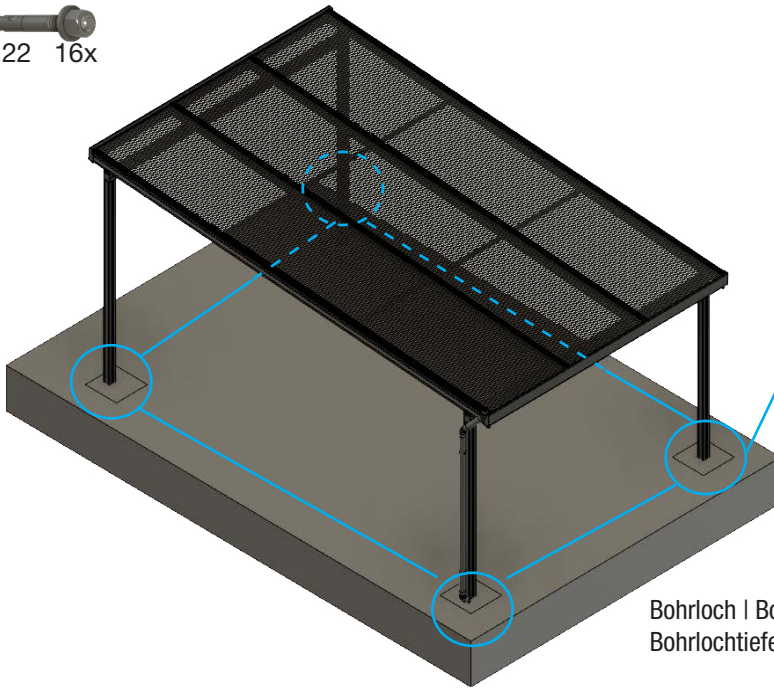

Bohrloch | Borehole | Trou de forage:  $d_0 = 12\text{ mm}$   
 Bohrlochtiefe | Borehole depth | Profondeur du trou de forage:  $h_1 > 90\text{ mm}$   
 Drehmoment | Torque | Couple:  $T_{inst} = 50\text{ Nm}$

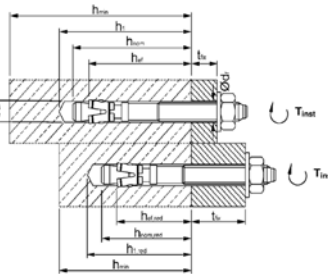

Dübelgröße		M12
Bohrerinnendurchmesser	$d_0 =$ [mm]	12
Bohrerschneiddurchmesser	$d_{cut} \leq$ [mm]	12.5
Drehmoment beim Verankern (galvanisch verzinkt)	$T_{inst} =$ [Nm]	50
Drehmoment beim Verankern (feuerverzinkt)	$T_{inst} =$ [Nm]	40
Durchgangsloch im Anbauteil	$d_1 \leq$ [mm]	14
Standardverankerungstiefe		
Bohrlochtiefe	$h_1 \geq$ [mm]	90
Setztiefe	$h_{setz} \geq$ [mm]	82
Verankerungstiefe	$h_{ver} \geq$ [mm]	65
Reduzierte Verankerungstiefe		
Bohrlochtiefe	$h_{1,red} \geq$ [mm]	75
Setztiefe	$h_{setz,red} \geq$ [mm]	67
Reduzierte Verankerungstiefe	$h_{ver,red} \geq$ [mm]	50

Die Betonanker sind ausschließlich zur Befestigung der Bodenplatten an den vorgesehenen Fundamentpunkten zu verwenden. Die in der Tabelle stehenden Montagehinweise müssen eingehalten werden. Bei unsachgemäßer Handhabung kann kein Garantieanspruch geltend gemacht werden.

The concrete anchors are to be used exclusively for fixing the floor plates to the intended foundation points. The installation instructions in the table must be observed. No warranty claim can be made in case of improper handling.

Les ancrages en béton doivent être utilisés exclusivement pour fixer les plaques de sol aux points de fondation prévus. Les instructions d'installation figurant dans le tableau doivent être respectées. Aucune réclamation de garantie ne peut être faite en cas de manipulation incorrecte.

20.  M 1x

Regenablauf kann wahlweise links, rechts oder vorne montiert werden.

Rain drain can be either left, right or can be mounted at the front.

L'évacuation de l'eau de pluie peut être montée à gauche, à droite ou à l'avant.

