

HARMER®

BUILDING DRAINAGE

Uniclass	
L73141:P41:P421:P43	
CI/SfB	lh1
	lh2
(52.5)	lh4

May 2019

HARMER SML

Cast Iron Above & Below Ground Soil & Waste System

Technical Brochure



CE



HARMER SML Cast Iron Above & Below Ground Soil & Waste System

Technical Brochure





Alumasc is a UK-based supplier of premium building products. The majority of the group’s business is in the area of sustainable building products which enable customers to manage energy and water use in the built environment.

Alumasc Water Management Solutions provide ‘Rain to Drain’ solutions, that set the standard for urban water management. They include: **Skyline** Fascias, Soffit & Copings; **Alumasc Rainwater** Gutters & Downpipes; **Harmer** Building Drainage; **Gatic** Civil Drainage & Access Covers and **Wade** Building Drainage.

Under the AWMS banner, customers benefit from rainwater and drainage products that capture, retain and control the flow of rainwater in the most effective way inside and outside buildings.



Introduction

Alumasc and Harmer - Introduction	4
Quality and Sustainability	5
The Harmer SML Solution: Above & Below Ground Drainage	6
The Harmer SML System	8
Integrated Drainage Solutions	10
Benefits of the Harmer SML System	11
Benefits of Modern Cast Iron	12
Harmer SML Product Range Overview	14
Harmer SML Drainage System - Project Gallery	16

Harmer SML Above Ground Range

Introduction	18
Product Range Summary	19
Product Range Items	20
Pipes and Pipe Couplings	21
Pipe Couplings	22
Pipe Brackets	23
Pipe Fittings - Bends	25
Pipe Fittings - Bends and Offsets	27
Pipe Fittings - Branches	28
Pipe Fittings - Access	31
Pipe Fittings - Miscellaneous	32
Pipe Adaptors	36
Fixing Tools and Touch Up Paint	37

Harmer SML Below Ground Range

Introduction	38
Product Range Summary	39
Product Range Items	40
Pipes, Pipe Couplings, Brackets	41
Pipe Fittings - Bends	42
Pipe Fittings - Branches	43
Pipe Fittings - Access	44
Pipe Fittings - Miscellaneous	45
Inspection Chambers, Gully, Solid Plate, Grate	46
Fixing Tools and Touch Up Paint	47

Harmer SML Technical Data

Introduction	48
Pipe Standards, Usage and Performance	49
Inherent Acoustic Performance	51
Inherent Fire Performance	52
Coupling Usage	54
Coupling Performance and Electrical Continuity	55
Bracket Usage and Performance	56

Harmer SML Installation

Introduction	58
Fixing Tool Requirements	59
Installation Above Ground - Ductile Iron Coupling	60
Installation Above Ground - Stainless Steel Coupling	61
Installation Below Ground - Ductile Iron Coupling	62
Installation Below Ground - Stainless Steel Coupling	63

Harmer SML Application

Introduction	64
Above Ground Considerations	65
Below Ground Considerations	66
Vertical Pipe Support	68
Horizontal Pipe Support	70
Connection to Other Materials	71
Manifold Connections	73
Other Connections	74

Harmer SML Guidelines to NBS Specification

Above Ground Standard Clauses for Typical Installation	75
Below Ground Standard Clauses for Typical Installation	76

Other Harmer Drainage Products

77

Alumasc Water Management Solutions

79





Alumasc Water Management Solutions (AWMS) is part of the Alumasc Group plc. The Alumasc Group provides premium products, systems and solutions for specialist markets.



Roofing & Water Management



Architectural screening, Solar Shading & Balconies



Housebuilding products & Ancillaries

Almost 80% of group sales are driven by building regulations and specifications (architects and structural engineers) because of the performance characteristics offered

Over 90% of group sales relate to one or more of the following long-term strategic growth drivers:

- Energy management
- Water management
- Bespoke architectural solutions
- Ease of construction (including off-site construction)

Our strategy is enabling us to outperform the UK construction market, and we are leveraging this through growth in export sales

All Alumasc businesses have strong positions and brands in their individual specialist markets. We have five business segments:



BIM Overview

Alumasc have now created BIM (Building Information Modelling) files for the core Harmer Building Drainage Range.

All AWMS BIM files to date have been created using Autodesk Revit 2015, allowing users the freedom to work in Revit 2015 or more recent versions of the software. BIM files created are Revit 'Family' files.

All of the AWMS Harmer BIM files are modelled to achieve an accurate external space envelope and connection detail, but with file sizes that increase with model detail, they have been stripped of non-essential details such as logos, small radii, internal strengthening ribs, fasteners & fixings.

Services and Support

Alumasc leads the way in the field of construction product and system manufacture and the delivery of proven solutions. This success is founded on three key areas:

Premium Products

A constantly evolving range of quality proven, world class products and systems, fully accredited to UK, European and North American Standards.

Technical Support & Resources

Technical Support

Comprehensive data for specification and use of all products and systems is available in published form, and on the company website. This is backed by proactive support on a project basis, led by specialist area managers and using the latest CAD and BIM technology.

Alumasc Resources

An enthusiastic and committed workforce backed up by professional management and sales teams.

State-of-the-art and quality accredited production facilities with factory finishing.

A carefully developed and nurtured supply chain for world-class products to complement the in-house manufacture and to ensure a fully rounded and comprehensive offer for drainage and exterior systems.

A strong research and development capability.

Technical support for design and costing, based on the latest CAD and BIM technology and a comprehensive range of technical literature.



The full spectrum of assessment procedures and quality control standards have been employed by Alumasc to monitor the manufacture and performance of its cast iron products and systems, ensuring a responsible engagement with customers and the environment.

Harmer SML Product Testing and Certification

Standards	Description
BS EN 877	European standard for cast iron pipes and fittings
BBA	British Board of Agrément certificate 05/4191
BSI	British Standards Institute Kitemark KM613802
CE Mark	European conformity
BS EN 12056	Gravity drainage systems inside buildings Part 3 roof drainage layout and calculation
EN 752	Drain and sewer systems outside buildings
EN 1610	Construction and testing of drains and sewers
BS EN 1253-1	Gullies for buildings. Requirements
BS EN 1253-2	
BS EN 1561	Founding - Grey cast irons
BS 13501-1	Reaction to Fire
BS EN ISO 1182	Non combustability
BS EN ISO 1716	Heat combustion (Calorific Value)
BS EN 13823 + A1	Single Burning Item (SBI)
DIN 19522	Cast iron drainage pipes and fittings without socket
ISO 6594	
BS EN 681	Elastomeric seals
ISO 4633	
BS EN 14366	Laboratory measurement for noise from waste water installations
BS EN ISO 14001	Environmental Management
BS EN ISO 9001	Quality Management



Alumasc Environmental Policy

In addition to complying with environmental legislation, Alumasc is committed to developing its own measures to limit the adverse effects of its activities on the environment. To this end, Alumasc operates an environmental policy across all sites that fully integrates all aspects of company activities.

The Alumasc environmental policy sets the standards for site emissions, noise levels, vibrations, and also systematically assesses the introduction of new processes and procedures.

Environmental Protection

BS EN ISO 14001, *Manufacturing to Environmental Standards.*

Grey cast iron is 100% recyclable. Pipe cuttings can also be included in recycling because the internal coating is free from benzopyrene and other environmentally dangerous materials.

Trade Bodies

Harmer Drainage is a patron member of the Chartered Institution of Building Services Engineers (CIBSE) and the Society of Public Health Engineers (SoPHE).

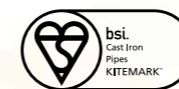

BRE Green Guide to Specification

The Green Guide to Specification provides easy-to-use guidance on making the best environmental choices when selecting construction materials and components. Materials and components are assessed in terms of their environmental impacts, within comparable specifications, across their entire life cycles. This accessible and reliable information has been put together to assist those involved in the design, construction and management of buildings to reduce the environmental impacts of their properties.

BREEAM

High quality, long lasting products reduce the significant environmental and monetary cost of replacement during service life. Alumasc goods are able to contribute fully to achieving BREEAM credits for responsible sourcing of materials and as part of an overall water management scheme.

The Harmer SML Solution for above & below ground

The Harmer SML system, with its comprehensive range of fittings and accessories, offers an innovative, whole-building solution for soil, waste and rainwater drainage installations.

The system is fully compatible with other market-leading Harmer and Wade drainage products, including roof, floor, shower and channel drains.

The hospital building shows just some of the SML components available, including other compatible Harmer drainage systems.

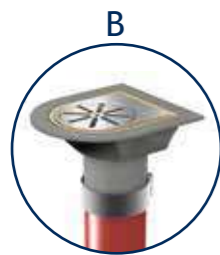
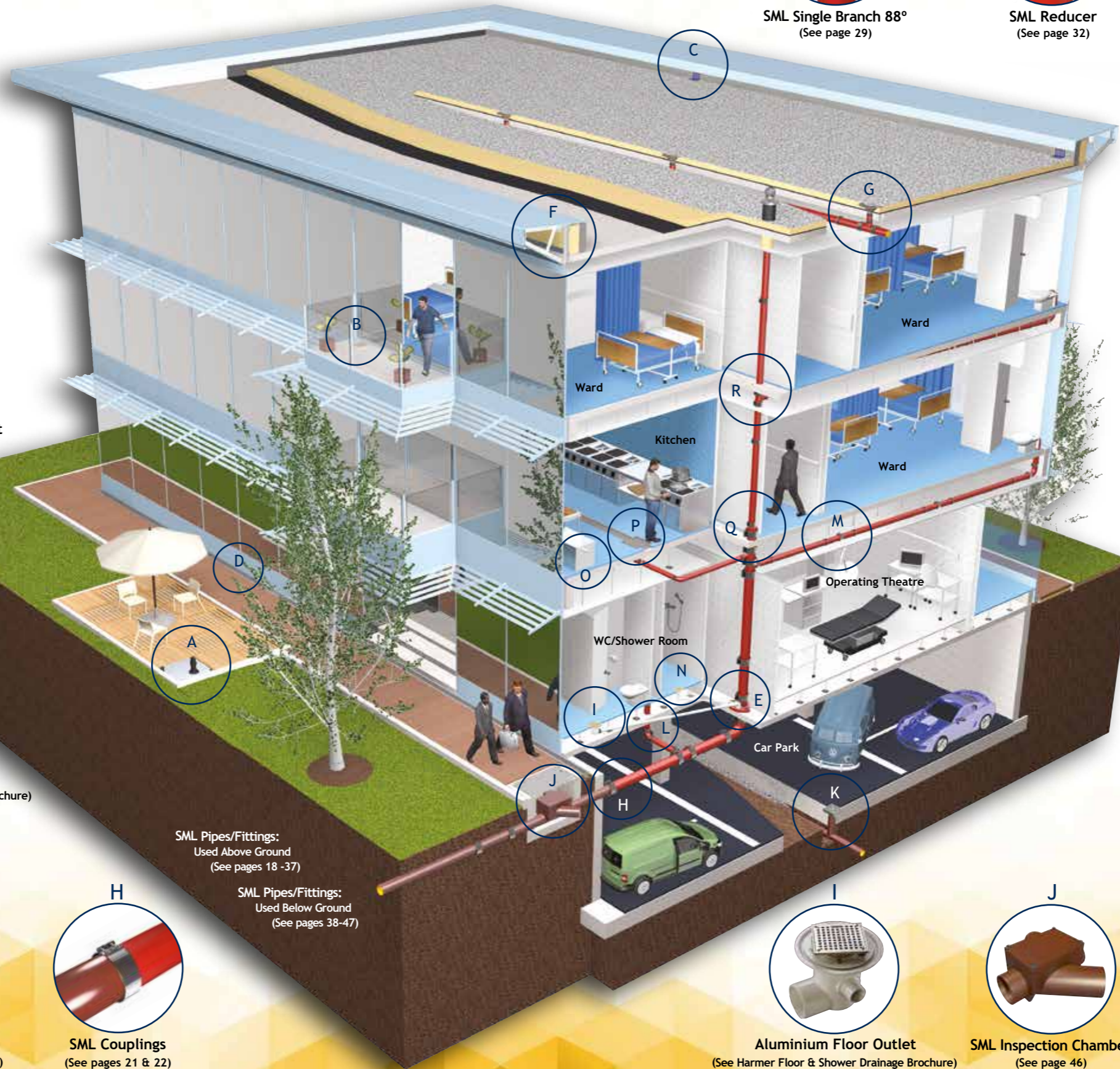

B
Aluminium Balcony Outlet
(See Harmer Roof Drainage Brochure)



A
Modulock Raised Deck Support
(See Harmer Roof Drainage Brochure)

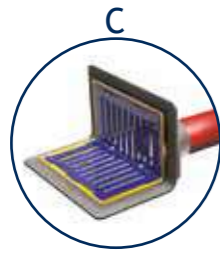

C
Aluminium Two-way Outlet
(See Harmer Roof Drainage Brochure)

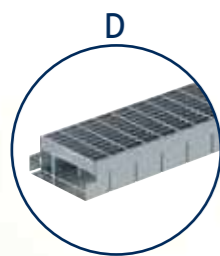

D
Modulock Channel Drain
(See Harmer Roof Drainage Brochure)



E
SML Manifold Connection
(See page 34)



G
Aluminium Roof Outlet
(See Harmer Roof Drainage Brochure)



H
SML Couplings
(See pages 21 & 22)

F
Skyline Fascias & Soffits
Standard and Bespoke
(See Skyline Architectural Fabrications Brochure)

SML Pipes/Fittings:
Used Above Ground
(See pages 18 -37)

SML Pipes/Fittings:
Used Below Ground
(See pages 38-47)



R
SML Single Branch 88°
(See page 29)



Q
SML Reducer
(See page 32)



P
Stainless Steel Floor Channel
(See Harmer & Wade Floor & Shower Drainage Brochure)



O
Grease Converter
(See Wade Grease Converters Brochure)



N
Aluminium/ABS Shower Drain
(See Harmer Floor & Shower Drainage Brochure)

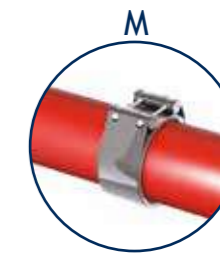

M
SML High Pressure Coupling
(See page 22)

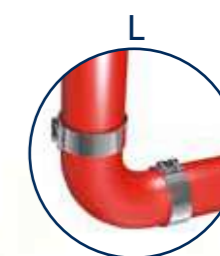

L
SML Single Bend 88°
(See page 26)



I
Aluminium Floor Outlet
(See Harmer Floor & Shower Drainage Brochure)



J
SML Inspection Chamber
(See page 46)



K
Cast Iron Floor Outlet & Grate
(See Harmer & Wade Floor & Shower Drainage Brochures)

The Harmer SML System

The Harmer SML lightweight cast iron pipework system is dry-jointed, BBA certified, and has a proven track record. With its comprehensive range of fittings and accessories, Harmer SML is the ideal soil and waste system for above and below-ground drainage, including rainwater installations, and is fully compatible with other Harmer drainage products.

All-Round Flexibility

The Harmer SML system consists of coated, socketless cast iron pipes and fittings simply joined with either ductile iron or stainless steel rubber-lined couplings. The range also includes bracketry for restraining the pipework vertically and supporting it horizontally, along with a choice of special connectors for linking with other materials.

Harmer SML provides value for money throughout the building life cycle, incorporating high performance materials, ease of installation and ease of access for maintenance.

Consequently, the Harmer SML system continues to be successfully used in market sectors ranging from hospitals, healthcare premises, commercial premises, offices, schools, industrial projects to civil engineering works and housing.

All-Round Standards

Harmer SML fully conforms to BS EN 877, the European standard for cast iron pipes and fittings along with conformity with the CE mark.

In addition, Harmer SML has been awarded a British Board of Agrément certificate for couplings, pipes and fittings.

A correctly installed Harmer SML system will meet the performance standards set by BS EN 12056, the code of practice for gravity drainage systems that covers sanitary pipework and roof drainage inside buildings. The Harmer SML system also meets the performance standards for drain and sewer systems outside buildings as set by EN 752.

Consequently, the SML drainage pipe system is eminently suitable for all drainage applications required within buildings in the UK. SML is also officially approved for use in numerous other countries including Australia, the Czech Republic, Denmark, Finland, Germany, Hungary, Norway, Russia, Singapore, Sweden, Switzerland and the Ukraine.



Key Features of Harmer SML

A proven, Agrément certified system which meets the European standard BS EN 877.



Excellent acoustic performance – tested in accordance with BS EN 14366: 2004.

Non-combustible.

High tensile strength.

Excellent compressive strength.

Choice of ductile iron or stainless steel couplings.

Secure socketless fixing between pipe and fitting.

The internal epoxy coating applied to above and below-ground pipes enables drainage systems to perform under extremely demanding chemical conditions.

External anti-corrosive coatings are also applied to above and below-ground pipes and fittings.

Low maintenance.

100% recyclable.

Quick to assemble.

Component Key

The examples shown of pipe fittings, brackets, couplings and supports are a very small selection of the wide range of components available in the Harmer SML drainage system.

Some compatible components from other Harmer drainage systems are also shown.

- A** Above Ground Pipework
- B** Below Ground Pipework
- 1** Duo Stainless Steel Coupling
- 2** Single Branch 88° 100mm connection
- 3** Cast Iron Vertical Spigot Roof Outlet with Domical Grate
- 4** Ductile Iron Coupling - above ground
- 5** Long Radius Bend 88°
- 6** Optimal Bracket with Wall Plate
- 7** Stack Pipe Support Bracket with Downpipe Support
- 7a** Stand Pipe Support Bracket as alternative to Stack Pipe Support
- 8** Cast Iron Pipe Adaptor with Floor Outlet comprising Trap, Stainless Steel Grate and Bezel
- 9** Ductile Iron Coupling - below ground
- 10** Round, Square and Rectangular Inspection Chamber options
- 11** Rest Bend

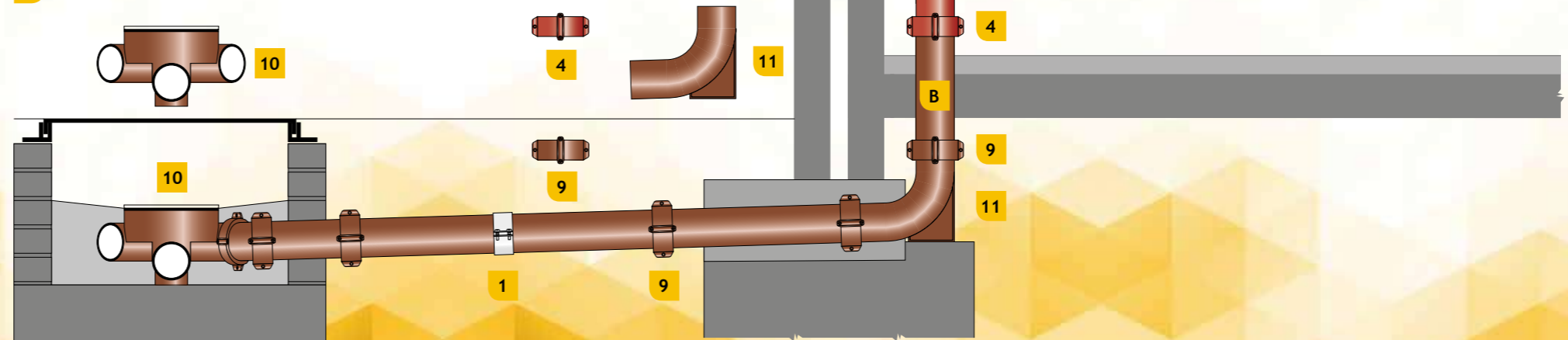

The Harmer SML system is fully compatible with Alumasc's ranges of Aluminium, Cast Iron and Insulated Roof Outlets, Aluminium Floor Drains, Aluminium and ABS Shower Drains, and Modulock Linear Channel Drains - enabling flexible design solutions to be found for all soil, waste and rainwater drainage configurations. Harmer SML is also supported by Alumasc's wide-ranging technical expertise and resources.

The Compatible Ranges

Harmer AV Aluminium Roof Outlets are high performance advanced flow vertical spigot and threaded outlets with circular flanges, suitable for all regular flat roofing applications with continuous membranes. AV Retro-Gully outlets are also available for refurbishment work. Grates incorporate a special patented baffle, which prevents water swirl and air entrapment, for optimum flow performance even in extreme rainfall conditions. Non-standard pipe and rainwater outlet configurations can be made on a bespoke basis to suit complicated designs.

Harmer Detail Aluminium Roof Outlets are used to cover all the awkward detailing situations that occur in building design and refurbishment. The range includes spigot and threaded outlets with 45° or 90° take-off, balcony outlets, gully outlets, car park outlets, and two-way outlets where the roof surface abuts a wall or parapet. Bespoke manufacture is also available.

Harmer and Wade Cast Iron Roof Outlets provide a practical solution to many building drainage applications. Available in medium sump and large sump bodies, two-way outlets, and an extensive range of load bearing grates and accessories.

Harmer and Wade Floor Drains offer the widest choice of materials, styles and capacities on the market. The full range extends across three principal material types: cast iron, aluminium and stainless steel. Drains can be supplied trapped or untrapped. They are available with an extensive range of grates (including round, square, slot and linear configurations) available in stainless steel, nickel bronze or ductile iron. The stainless steel offer comprises both Standard and Compact units, and a range of Standard and Custom Channels, designed with either slots or grates. All Harmer floor drains can be configured and designed to suit all types of floor construction and finish.

Harmer Shower Drains high-performance, antimicrobial aluminium, ABS, and stainless steel shower channels and outlets, for concrete or timber floors in both new build and refurbishment projects. A wide choice of attractive caps and grates is available to complement and enhance any shower or wet room design.

Harmer Modulock Linear Roof Channel Drains are designed to provide the ideal level access drainage solution where rainwater run-off and percolation are required to be intercepted at the perimeter of a building, or across thresholds and points of access into buildings, and then ducted away to drainage outlets. These advanced, linear, steel drainage ranges are designed for use within a raised deck structure. Combining threshold drainage with the level access requirements of the Building Regulations, Part M, these linear channel drains are particularly suited for use in combination with Harmer Modulock Raised Deck Supports.



Harmer and Wade Cast Iron Floor Drains



Harmer and Wade Stainless Steel Floor Drains



Harmer Aluminium Roof Outlets

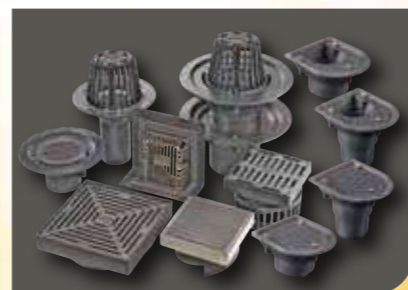

Harmer and Wade Cast Iron Roof Outlets

The Harmer SML socketless lightweight cast iron soil and waste system is BBA certified and meets the Standard of BS EN 877. The SML system combines modern, state-of-the-art drainage technology with the unique characteristics and benefits of cast iron as a preferred material for drainage installations.

Fire Safe

Non-combustible, therefore does not require costly fire protection collars.

Harmer SML has the highest product reaction to fire classification as A1 for BS EN 13501-1 as well as a system fire classification as A2 for BS EN 13823 Single Burning Item A2,s1-d0.

Robust

Lightweight, strong and durable.

High tensile strength and excellent compressive strength.

Totally secure socketless fixing between pipe and fittings.

Fit for Purpose

High resistance to positive and negative pressure – axial restraint up to 10 bar possible, therefore no need to change material in sensitive areas.

No expansion joints, deflection bends or other special expansion control techniques are required for the dimensionally stable pipes due to the low coefficient of thermal expansion of cast iron.

Quiet

Excellent acoustic performance, Harmer SML has been tested in accordance with BS EN 14366: 2004 – the latest test for acoustic performance of building materials.

Typically, no special sound insulation measures required.

Easy and Quick to Install

Assembled by means of twin screw couplings.

Easily connects to other materials via push-fit couplings.

No special installation equipment required.

No specialist experience required.

Low Maintenance

Epoxy coatings ensure pipes and fittings need minimal maintenance over the lifetime of a drainage installation.

Inherent resistance to external accidental damage and vandalism.

Value for Money

Less fixing necessary, as fewer brackets are required because of greater pipe spanning capability.

Cast iron has a proven track record for its longevity over the lifetime of a building.

Sustainable

Long life cycle (40 Years)

100% recyclable material, therefore all waste can be returned to the furnace to make new cast iron products.



Stainless Steel Coupling



Ductile Iron Coupling

For centuries, cast iron has been a preferred material for building construction because of its longevity in a wide range of applications. Advances in cast iron technology have ensured that today's products are fully attuned to modern construction needs.

High Strength and 21st Century Technology

The crystalline structure of cast iron gives the material high strength and robustness. Once installed, cast iron components resist impact damage and are therefore well suited to installation in potentially exposed areas, such as car parks, schools, shopping centres, and busy public buildings such as hospitals, indeed in any situation where heavy wear and impact can be expected.

Cast iron's high carbon content (2%-4%) makes it a very suitable material for casting pipes and other cylindrical components by pouring molten iron into permanent moulds, which are spun at high speed. The liquid is forced into the side of the mould lining, producing a casting that has a uniform wall thickness. As a result of this centrifugal force, the iron becomes denser and stronger than gravity cast iron, making it particularly well suited to drainage applications because pipes can be made in longer lengths.

Durability

Cast iron is not susceptible to changes in its material structure or composition over time and will therefore remain serviceable over longer periods when compared with other materials.

As a material, cast iron is extremely stable and therefore durable, and is not susceptible to environmental, chemical or mechanical stresses. Historically, cast iron has been shown to offer long and reliable service because of its stable mechanical properties over time.

Cast iron is not susceptible to deterioration under variable thermal conditions because its mechanical strength remains stable and unaffected by temperature change. As a material for drainage installations, cast iron offers significant benefits over plastics-based material in event of fire.

The two-part epoxy coating of the internal surface of Harmer SML pipe and the anti-corrosive primer external coating ensure that the Harmer SML system will require minimal maintenance during its installed lifetime. Cast iron is the ideal material for inaccessible or difficult-to-reach areas and therefore particularly suited to below-ground drainage installations.

Temperature Extremes and Linear Expansion

Cast iron's low coefficient of thermal expansion (0.0105 mm/m/K) means that components made from it can be subjected to extreme temperatures without distortion, thereby requiring no costly expansion joint provision to take up differential movement. This is particularly beneficial where cast iron components are used in conjunction with concrete structures (concrete has an almost identically low coefficient of thermal expansion).

Cast iron has a very low level of thermal expansion in comparison with plastic drainage. Cast iron pipework is not liable to creep at operating temperatures.

Mechanical Stability

Cast iron does not deform under mechanical strain. Its stiffness and stability are unaffected by temperature and are around eight times greater than that of plastic pipework. The tensile strength of cast iron is similarly superior to that of plastics.

The demand for building land has increased the need to utilise reclaimed ground or sites in areas where there may be ground movement. Cast iron is the ideal material for below ground drainage installation because it offers greater resistance to chemical attack, degradation and ground movement.



Centrifugal casting process



In addition to strength, durability, mechanical stability and superior fire resistant qualities, cast iron offers yet more benefits in terms of performance and environmental sustainability.

Acoustic Performance

The crystalline nature of cast iron gives the material a very high damping capacity thereby significantly reducing noise transmission through cast components installed within building structures.

Additional sound protection will not normally be required in Harmer SML drainage installations as regards water flow within the pipework. In above-ground installations, the Harmer SML system of support and bracketry keeps pipework away from direct contact with surfaces, which reduces likelihood of sound transmission through the building structure.

For more detailed information refer to the 'Technical Data' section, page 51.

Fire Performance

In drainage installations, safety in case of fire is the primary health and safety concern, both in terms of material properties and reaction in fire, and fire resistance to prevent collapse.

Cast iron is non-combustible and therefore does not propagate fire nor emit toxic gases, unlike plastics-based systems. Consequently, installed cast iron components do not require costly fire protection measures.

For more detailed information refer to the 'Technical Data' section, pages 52-53.

No Thermal Ageing

The Harmer SML system offers long and reliable service because cast iron is a stable material over time. Cast iron is not susceptible to thermal ageing.

Economy and Functionality

Modern lightweight cast iron provides an economical and functional material solution for soil and waste drainage. Fewer fixings and support brackets are required for lengths of cast iron pipe, in comparison with pipework of other materials, which contributes to the cost competitiveness of cast iron. There is no requirement for expansion joints, deflection bends, or any other expansion control measures.

Environmental Considerations

Cast iron has a long useful life cycle - far longer than plastics, which degrade over time - and therefore represents a sustainable use of a building material. It is environmentally friendly with no negative impacts on the environment and is 100% recyclable.

Cast iron does not emit any volatile organic compounds (VOCs), which are extremely hazardous and pose dangers to health, including eye, nose and throat irritation, frequent headaches, nausea, and can also damage the liver, kidneys and central nervous system.

Recycling cast iron benefits the environment because all scrap iron can be returned to the furnace, rather than going to landfill. New cast iron products can be created utilising recycled scrap. The resultant products are of high quality because when cast iron is recycled there is no diminution in its inherent characteristics and functional performance. This is in marked contrast to products made from recycled plastic because, when plastic is recycled, its quality decreases markedly. Cast iron, unlike plastic, is both environmentally friendly and maintains its beneficial characteristics when recycled.



All pipes and fittings for Harmer SML above and below-ground soil and waste drainage are fully compatible and comply with BS EN 877*. They are durable, low-maintenance, recyclable, and quick and easy to install. Manufacture is under strict factory-controlled conditions to meet the highest performance standards.

* Cast iron pipes and fittings, their joints and accessories for the evacuation of water from buildings. Requirements, test methods and quality assurance.



Pipes, Couplings and Brackets

The pipes, in standard 3m lengths and in a choice of diameters from 50mm to 400mm, are connected to each other and to a wide range of bends and branches with stainless steel or ductile iron couplings for any proposed drainage system. Above and below-ground pipes are differentiated by colour.

Maintaining the stability of above-ground pipework is vital, and to this end Alumasc has developed a range of bracketry that supports both vertically and horizontally. The range includes vertical, horizontal hanging and stack support brackets, and fitted with sound-deadening rubber linings.

Harmer SML above-ground pipe has a two-part epoxy coating on the inside and anti-corrosion primer on the external surface. Harmer SML pipe for below-ground applications has the same material specification as above-ground pipework, but with a higher external coating specification to cope with aggressive ground conditions.

See pages 21 to 24 (above ground)
See page 41 (below ground)



Bends, Branches and Pipe Access Components

The large choice of bends and branches available enables any configuration of above and below-ground pipe layouts to be achieved with ease.

The range includes single bends, short and long tail double bends, long radius bends, rest bends, offsets, single and double branches, swept entry branches, corner branches and combination branches.

The range also includes access pipes and fittings designed for easy inspection and rodding.

Fittings such as branches, bends and offsets are coated internally and externally to the same specification as Harmer SML pipe.

See pages 25 to 31 (above ground)
See pages 42 to 44 (below ground)



Boss Pipes, Reducers, End Caps, Pipe Supports, Bearing Rings and Connectors

A complementary range of miscellaneous fittings is available for increasing the configuration possibilities of a drainage system.

See pages 32 to 34 (above ground)
See page 45 (below ground)



Wall Flanged Pipe, Traps, Adaptors and Puddle Flange

A complementary range of traps and adaptors in a variety of diameters is available for increasing the flexibility of use of a drainage system.

See pages 35 and 36 (above ground)
See page 45 (below ground)



Inspection Chambers, Gully, Plate and Grate

A range of inspection chambers to connect 100mm and 150mm diameter pipes with 45° branch connections. Supplied with removable covers allowing easy access for maintenance.

See page 46 (below ground)



Fixing Tools

A complete range of high quality fixing tools is available from Alumasc.

The Harmer Duomat fixing tool is recommended for securing Harmer Duo couplings. Bolts can be tightened simultaneously with precision.

See page 37 (above ground)
See page 47 (below ground)

Harmer Projects

The Harmer SML lightweight above and below-ground cast iron soil and waste system is ideal for specification across a wide spectrum of building types, including retail, commercial, civil, transport, sport, health and welfare. The Harmer SML system is fully compatible with other Harmer & Wade drainage ranges - including roof, floor and shower drains, and linear channel drains - for a fully integrated total building drainage solution.



Harmer SML Above Ground Range

The Above Ground range is part of the cast iron, dry-jointed pipework system complete with a comprehensive suite of fittings and accessories. Fully compatible with the Below Ground range.



Above Ground - Product Range Summary

All Harmer SML pipes and fittings comply with BS EN 877, being manufactured under strict factory-controlled conditions to meet the highest performance standards. They are durable, recyclable, quick and easy to install and require low maintenance.

Pipes

Harmer SML pipes are available in standard 3m lengths, in diameters of 50mm to 400mm, providing everything for high performance, lightweight cast iron soil and waste systems. Pipes have an exterior primer coating, minimum thickness 40 µm. The interior of pipes has an epoxy coating with a minimum thickness of 120 µm. See page 21.

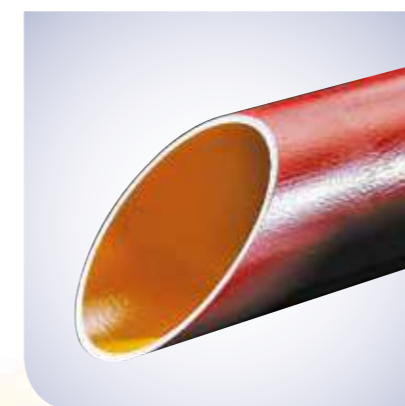
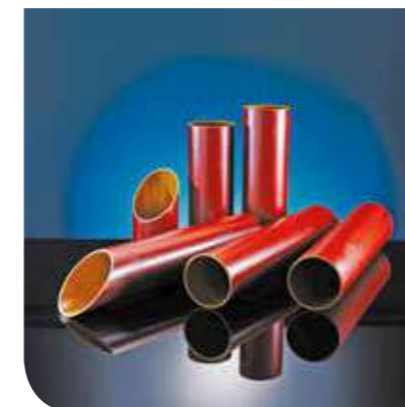

Branches

Fittings designed to accommodate connection of branch pipework to a principal vertical pipe stack. The available range includes single and double branches, swept entry branches, corner branches and combination branches. They are coated externally and internally with an epoxy coating, minimum thickness 60µm. See pages 28-30.



Bracketry

Maintaining the stability of above-ground pipework is vital, and to this end Alumasc has developed a range of support bracketry that supports both vertically and horizontally. The range includes vertical, horizontal hanging and stack support brackets, which are available in ductile cast iron, zinc plated or pre-galvanised, and fitted with sound-deadening rubber linings. See pages 23 and 24.



Bends and Offsets

A wide range of bends to accommodate change of direction, meeting a wide variety of design requirements, including single bends, short and long tail double bends, long radius bends, bends with spigots, rest bends and offsets. They are coated externally and internally with an epoxy coating, minimum thickness 60µm. See pages 25-27.



Access Fittings

Designed to allow access for inspection and rodding – includes circular access pipes, rectangular access pipes, access bends and branches. They are coated externally and internally with an epoxy coating, minimum thickness 60µm. See page 31.



Couplings and Adaptors

Harmer SML couplings are specially designed for joining lengths of Harmer SML pipe, and for joints between pipes and fittings. Couplings are available in stainless steel and ductile iron. Like Harmer SML pipes and fittings, all Harmer SML couplings have been subject to rigorous testing and meet the requirements of BS EN 877. See pages 21, 22 and 36.



Completing the Product Range

The range also includes boss pipes, reducers, end caps, downpipe supports, bearing rings, manifolds, connectors, flanged pipes, traps and fixing tools. See pages 32-35 and 37.



The complete range of Harmer SML pipes, pipe fittings, pipe couplings and pipe brackets will be found in the following list of product tables.



Pipes

All diameters in 3000mm lengths	21
---------------------------------	----

Pipe Couplings

Ductile Iron	21
Stainless Steel Duo	21
Grip	21
Adaptor	22
Combi Grip Collar EK	22
Rapid Coupling + Combi Grip Collar EK	22
Axilock-S High Pressure	22

Pipe Brackets

Ductile Iron	23
Optimal	23
Optimal HD	23
Hanging	23
Acoustic Dampener (dB Fix)	24
Stack Pipe Support	24
Stand Pipe Support	24

Pipe Fittings (Bends & Offsets)

Single Bends 15°	25
Single Bends 30°	25
Single Bends 45°	25
Single Bends 68°	25
Single Bends 88°	26
Short Double Bends 88°	26
Long Double Bends 88°	26
Long and Medium Radius Bends 88°	26
Bends with Long Tails 45°	27
Bends with Long Tails 88°	27
Bends with Long Tails 135°	27
Rest Bend	27
Offsets	27

Pipe Fittings (Branches)

Single Branches 45°	28
Single Branches 68°	28
Single Branches 88°	29
Double Branches 45°	29
Double Branches 68°	29
Double Branches 88°	29
Swept Double Branches 88°	30
Corner Branches 45°	30
Corner Branches 88°	30
Combination Branches	30

Pipe Fittings (Access)

Round Access Pipes	31
Rectangular Access Pipes	31
Long and Short Access Bends 88°	31
Swept Entry Branches 88°	31

Pipe Fittings (Miscellaneous)

Boss Pipes 88°	32
Reducers	32
Downpipe Supports	32
End Caps – Blank Ends	33
End Caps – Tapped	33
End Caps – Plug	33
Bearing Rings	33
Manifold Connectors	34
Sleeved Connectors	34
Stoneware Connectors	34
Flanged Connectors	34
Pipe with Wall Flange	35
Branch Traps	35
Plain Trap	35
Rainwater Stench Traps	35

Pipe Adaptors

Konfix Single (Waste adaptor)	36
Konfix Multi (Waste adaptor)	36

Fixing Tools/Touch Up Paint

Harmer Duomat Tool	37
1/2" Drive Tools	37
3/8" Drive Tools	37
Touch Up Paint	37

Pipes

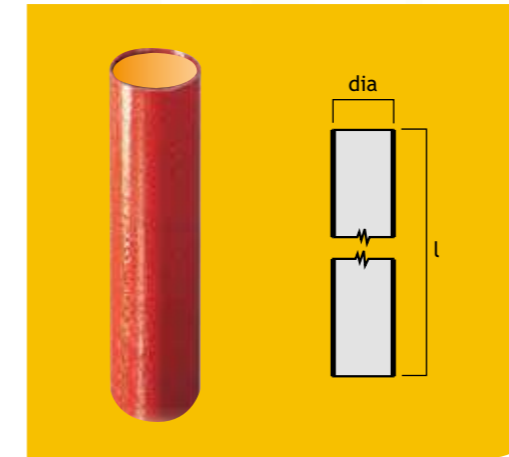

Pipe Dia (mm)	Pipe O/D (mm)	l (mm)	Nom Weight (kg)	Product Code
50	58	3000	15.8	660004
70	78	3000	20.0	660094
100	110	3000	25.6	660184
125	135	3000	35.0	660274
150	160	3000	42.8	660364
200	210	3000	71.5	660454
250	274	3000	91.0	660654
300	326	3000	125.2	660664
400	429	3000	175.5	660604

400mm dia pipe is available on request

Ductile Iron Couplings

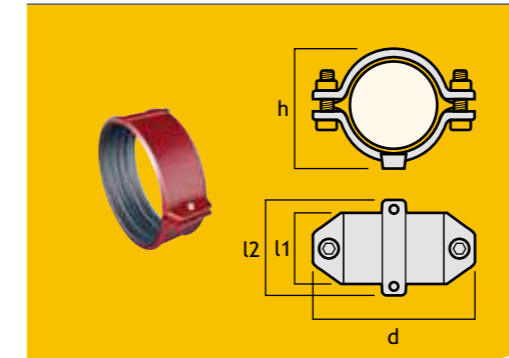

Pipe Dia (mm)	h (mm)	d (mm)	l1 (mm)	l2 (mm)	Nom Weight (kg)	Product Code
50	79	111	50	68	0.6	235849
70	89	132	50	68	0.7	235526
100	134	168	60	78	1.1	235537
150	184	230	71	89	1.9	235358
200	231	278	82	100	3.5	235527

Supplied with integral electrical continuity screws.

Stainless Steel Duo Couplings

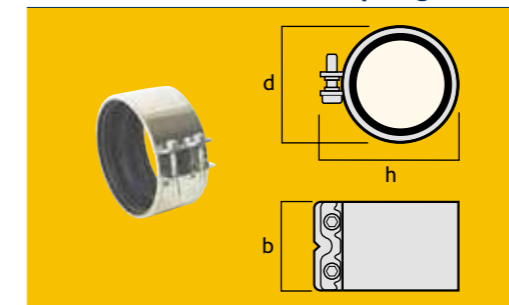

Pipe Dia (mm)	Bolts	d (mm)	h (mm)	b (mm)	Product Code
50	2	75	90	55	3140/50
70	2	95	110	55	3140/70
100	2	125	140	55	3140/100
125	2	125	165	70	3140/125
150	2	175	190	70	3140/150
200	4	220	255	70	3140/200
250	8	280	315	140	3140/250
300	8	335	370	140	3140/300

Supplied as standard with electrical continuity spur.
400mm coupling available on request

Grip Couplings

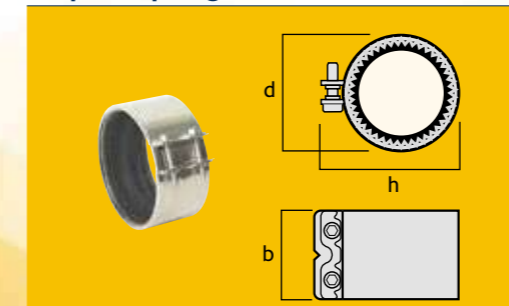

Pipe Dia (mm)	Bolts	d (mm)	h (mm)	b (mm)	Product Code
50	2	75	90	55	3176/50
70	2	95	110	55	3176/70
100	2	125	140	55	3176/100
125	2	125	165	70	3176/125
150	2	175	190	70	3176/150
200	4	220	255	70	3176/200

Offers increased pressure rating for unrestrained applications

All pipe coupling dimensions in above tables are average (coupling unfastened).



Adaptor Couplings

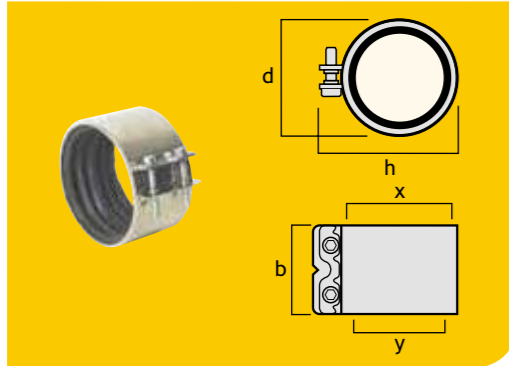

Pipe Dia (mm)	Bolts	d (mm)	h (mm)	b (mm)	x (mm)	y (mm)	Product Code
70*	2	95	110	70	83-84	75-76	3151/070075
100**	2	130	145	70	116-119	108-113	3102/100
150**	4	180	215	70	168	158-162	3102/150

Adapts lightweight 'soil' to conventional 'drain'.

*Connection of 3" SML to 3" Harmer/Wade roof outlets.

**Connection of SML EN 877 to BS 437 pipe.

Combi Grip Collar EK Couplings

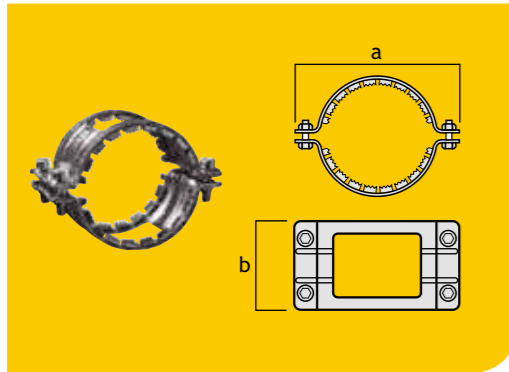

Pipe Dia (mm)	a (mm)	b (mm)	Product Code
50	124	72	235360
70	149	72	235498
100	180	85	235280
125	210	98	235315
150	230	98	235316
200	287	111	235281
250	267	130	216888
300	419	130	100304

Galvanised steel collar for use with associated double bolt Duo coupling (page 21) for increased pressure rating.

Rapid Coupling + Combi Grip Collar EK Couplings

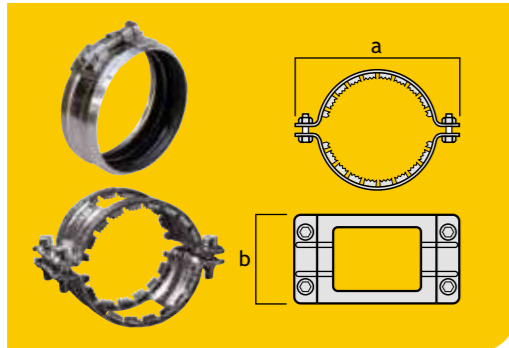

Pipe Dia (mm)	a (mm)	b (mm)	Product Code
50	124	72	218592/COMBI
70	149	72	218593/COMBI
100	180	85	214405/COMBI
125	210	98	218594/COMBI
150	230	98	218595/COMBI

Galvanised steel collar for use with single bolt Speed Fix stainless steel coupling for increased pressure rating.

Axilock-S High Pressure Couplings

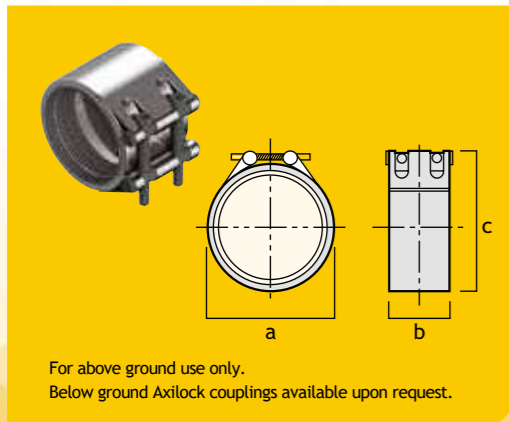

Pipe Dia (mm)	a (mm)	b (mm)	c (mm)	Torque (Nm)	Pressure	Allen Key (mm)	Bolt Size	Product Code
50	74	88	90	25	PN16	6	M8	ALS050
70	94	88	109	30	PN16	8	M8	ALS070
100	128	88	144	25	PN16	8	M10	ALS100
125	152	114	177	60	PN16	10	M12	ALS125
150	179	115	205	85	PN16	10	M12	ALS150
200	233	115	254	90	PN16	14	M16	ALS200
250	299	120	326	80	PN10	14	M16	ALS250
300	350	120	377	80	PN10	14	M16	ALS300
400	455	120	482	150	PN10	14	M16	ALS400

For above ground use only.
Below ground Axilock couplings available upon request.

For all pipe diameters: Gasket is manufactured from EPDM.
Drive socket size is 1/2".

All pipe coupling dimensions in above tables are average (coupling unfastened).



Ductile Iron Bracket (For Vertical and Horizontal Pipework Applications)

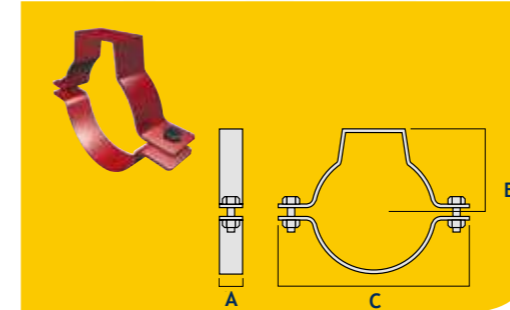

Pipe Dia (mm)	a (mm)	b (mm)	c (mm)	Nom Wt (kg)	Product Code
50	28	62	114	0.4	DB050
70	28	72	135	0.5	DB070
100	28	88	167	0.6	DB100
150	30.5	114	216	0.85	DB150
200	30.5	148	267	1.6	DB200

Optimal Bracket (For Vertical and Horizontal Pipework Applications)

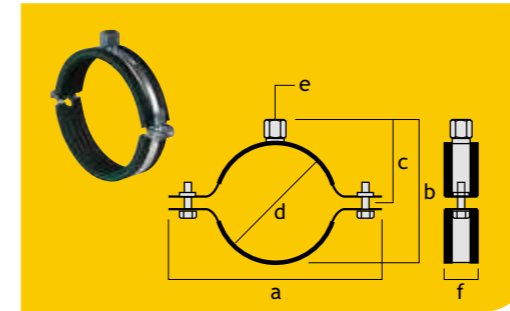

Pipe Dia (mm)	a (mm)	b (mm)	c (mm)	d (mm)	e (mm)	f (mm)	Nom Wt (kg)	Product Code
50	102	90	50	57-64	M8/M10	23	0.1	220012
70	127	110	60	73-80	M8/M10	23	0.2	220013
100	163	140	77	108-114	M8/M10	25	0.3	220014
125	190	170	90	133-141	M8/M10	25	0.35	220015
150	228	186	100	159-168	M10	25	0.4	220016
200	273	245	120	200-210	M10	25	0.5	220011

When used in vertical applications, additional stack support is required. (See pages 68 and 69)
Acoustically tested to EN 14366: 2004. (See page 51) For usage/performance see page 56.

Optimal HD Bracket (For Vertical and Horizontal Pipework Applications)

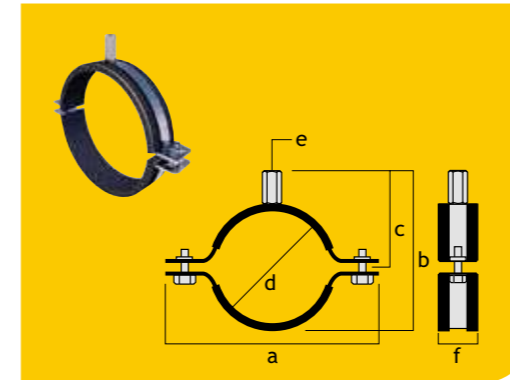

Pipe Dia (mm)	a (mm)	b (mm)	c (mm)	d (mm)	e (mm)	f (mm)	Nom Wt (kg)	Product Code
100	182	160	93	108-116	M10/M12	30	0.5	33143116
125	207	184	104	132-140	M10/M12	30	0.5	33143140
150	254	223	124	159-164	M10/M12	38	1.1	33143169
200	299	267	146	203-213	M10/M12	38	1.5	33143213
250	367	327	175	265-275	M16	48	2.5	33163275
300	453	412	217	315-325	M16	48	3.0	33163323

When used in vertical applications, additional stack support is required. (See pages 68 and 69)
Acoustically tested to EN 14366: 2004. (See page 51) For usage/performance see page 57.

Hanging Bracket – Pre Galvanised (For Horizontal Pipework Applications)

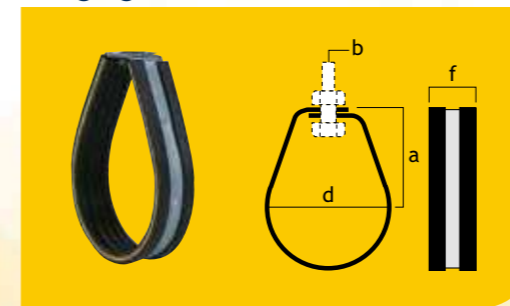

Pipe Dia (mm)	a (mm)	b*	d (mm)	f (mm)	Nom Weight (kg)	Product Code
50	60	M10	58	23	0.1	220045
70	95	M10	78	23	0.2	220046
100	110	M12	110	23	0.3	220047
125	140	M12	135	25	0.35	220048
150	150	M12	160	25	0.4	220049
200	190	M16	220	25	0.5	220050
250	242	M16	276	50	1.5	220051
300	265	M16	328	50	2.0	220052

*Bolt not supplied



Acoustic Dampener (dB-Fix)

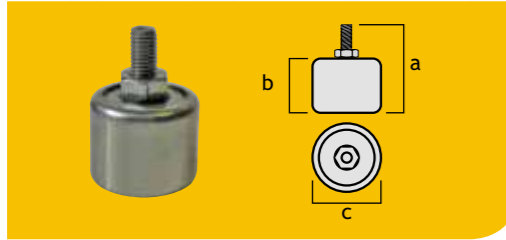

Type	a (mm)	b (mm)	c (mm)	Rod Size	Safe Load* (N)	Product Code
dB-Fix	60	34	40	M10	500	6697005

A noise insulating fixing point for use in acoustically protected installations, tested in accordance with EN 14366: 2004. (See page 51)

* Refers to pull down load (in horizontal pipework applications)

Stack Pipe Support Bracket (For Vertical Pipework Applications)

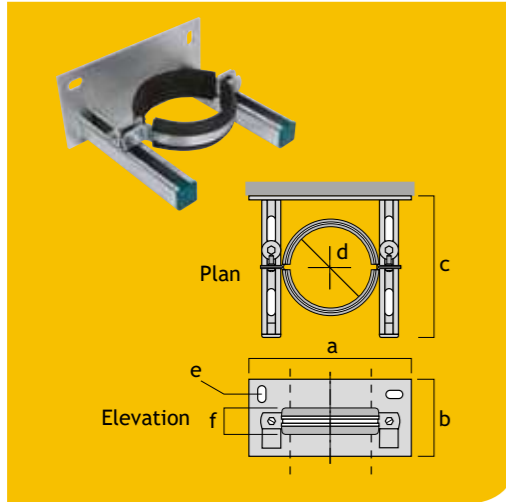

Pipe Dia (mm)	a (mm)	b (mm)	c (mm)	d (mm)	e (mm)	f (mm)	Nom Wt (kg)	Product Code
70	212	114	210	78	13x23	25	2.0	4323/70
100	244	114	210	110	13x23	25	2.2	4323/100
125	269	114	210	135	13x23	25	2.4	4323/125
150	293	114	210	160	13x23	25	2.6	4323/150
200	343	114	250	210	13x23	25	3.0	4323/200

To be used in combination with Downpipe Support. (See pages 32, 57 and 68-69)



(Shown with Downpipe Support fitting)

Stand Pipe Support Bracket (For Vertical Pipework Applications)

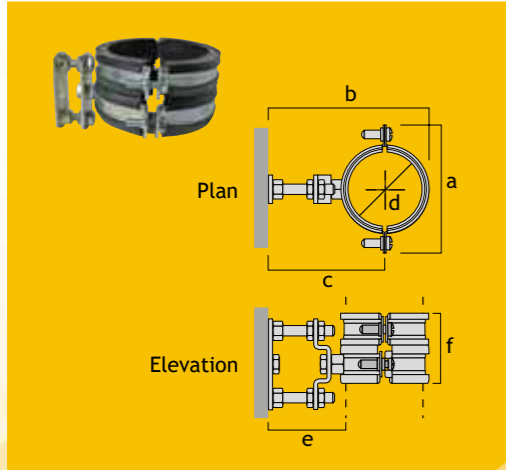

Pipe Dia (mm)	a (mm)	b (mm)	c (mm)	d (mm)	e (mm)	f (mm)	Nom Wt (kg)	Product Code
70	154	130-140	83-93	78	45-55	75	1.0	3363070
100	176	165-175	100-110	110	45-55	75	1.1	3363100
125	192	190-200	113-123	135	45-55	75	1.2	3363125
150	233	225-235	127-137	160	45-55	75	1.4	3363150

(See pages 57 and 68-69 for specification and installation details)

All pipe bracket dimensions and weights in above tables are average.



Single Bends 15°

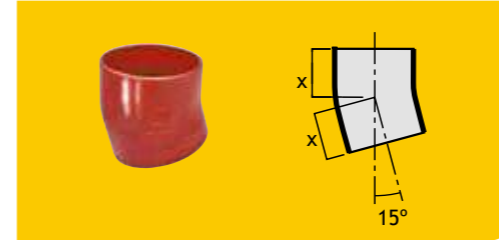

Pipe Dia (mm)	x (mm)	Nom Weight (kg)	Product Code
50	40	0.4	661004
70	45	0.6	661064
100	50	1.0	661124
125	60	1.7	661184
150	65	2.5	661244
200	80	4.6	661304

Single Bends 30°

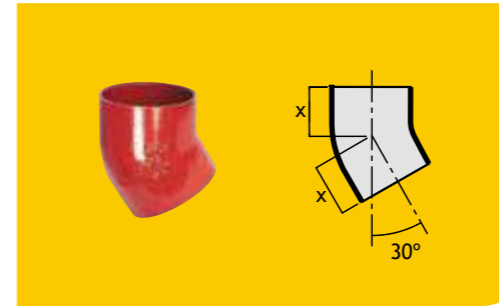

Pipe Dia (mm)	x (mm)	Nom Weight (kg)	Product Code
50	45	0.5	661014
70	50	0.7	661074
100	60	1.3	661134
125	70	2.0	661194
150	80	3.1	661254
200	95	5.2	661314
250	110	9.1	661364
300	130	14.7	661384

Single Bends 45°

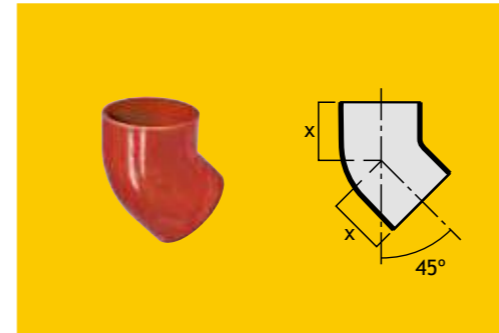

Pipe Dia (mm)	x (mm)	Nom Weight (kg)	Product Code
50	50	0.5	661024
70	60	0.9	661084
100	70	1.5	661144
125	80	2.3	661204
150	90	3.5	661264
200	110	5.5	661324
250	130	10.3	661374
300	155	17.0	661394
400	257	36.0	661284

400mm dia single bend is available on request

Single Bends 68°

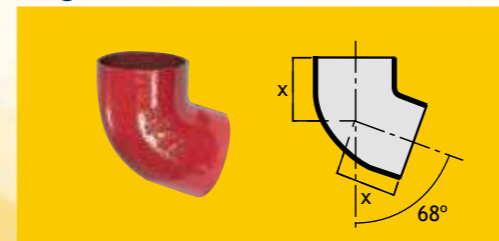

Pipe Dia (mm)	x (mm)	Nom Weight (kg)	Product Code
50	65	0.7	661034
70	75	1.1	661094
100	90	1.9	661154
125	105	2.9	661214
150	120	4.3	661274
200	145	7.7	661334



Single Bends 88°

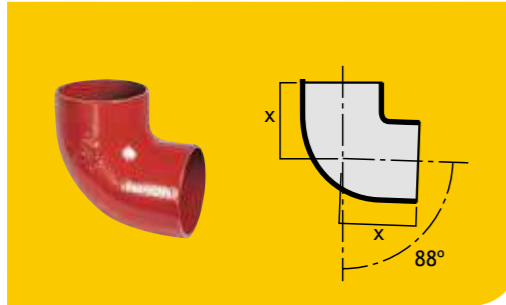

Pipe Dia (mm)	x (mm)	Nom Weight (kg)	Product Code
50	75	0.7	661054
70	90	1.1	661114
100	110	2.1	661174
125	125	3.2	661234
150	145	5.2	661294
200	175	8.8	662784
250	225	15.5	233621
300	260	25.5	233622

Short Double Bends 88°

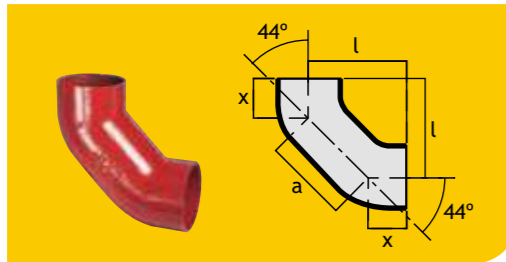

Pipe Dia (mm)	x (mm)	l (mm)	a (mm)	Nom Weight (kg)	Product Code
50	50	121	100	1.2	661484
70	60	145	120	1.8	661494
100	70	170	140	3.2	661504
125	80	195	160	4.6	661514
150	90	219	180	7.0	661524

Long Double Bends 88°

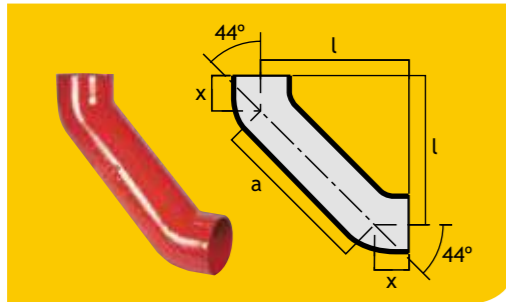

Pipe Dia (mm)	x (mm)	l (mm)	a (mm)	Nom Weight (kg)	Product Code
70	60	273	300	3.2	662734
100	70	291	312	4.8	662744
125	80	308	321	6.8	662754
150	90	325	333	9.6	662764

Long and Medium Radius Bends 88°

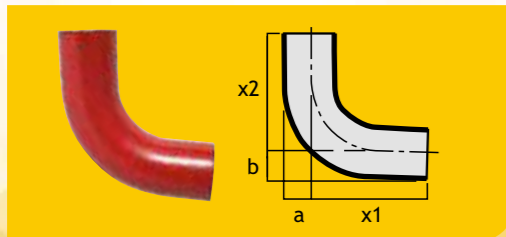

Pipe Dia (mm)	x1 (mm)	a (mm)	x2 (mm)	b (mm)	Nom Weight (kg)	Product Code
100*	230	55	230	55	5.1	235125
150**	245	80	245	80	7.8	235126

*Long radius bend **Medium radius bend
(The radius in both cases is 150mm)

Bends with Long Tails 45°

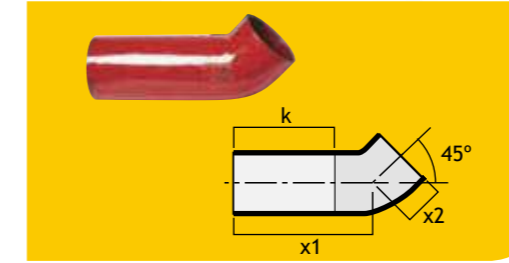

Pipe Dia (mm)	Angle°	x1 (mm)	x2 (mm)	k (mm)	Nom Weight (kg)	Product Code
70	45	250	60	190	2.6	662054
100	45	250	70	180	4.2	662074

k = dimension for maximum cut back

Bends with Long Tails 88°

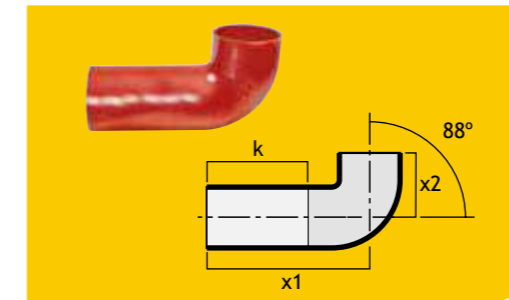

Pipe Dia (mm)	Angle°	x1 (mm)	x2 (mm)	k (mm)	Nom Weight (kg)	Product Code
70	88	250	90	160	2.8	662064
100	88	250	110	140	3.5	662084

k = dimension for maximum cut back

Bend with Long Tails 135°

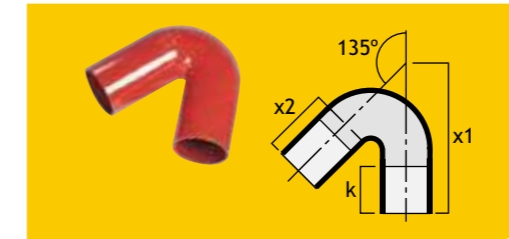

Pipe Dia (mm)	Angle°	x1 (mm)	x2 (mm)	k (mm)	Nom Weight (kg)	Product Code
100	135	312	150	100	5.0	662774

k = dimension for maximum cut back

Rest Bend

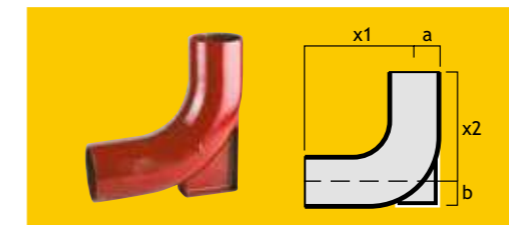

Pipe Dia (mm)	x1 (mm)	a (mm)	x2 (mm)	b (mm)	Nom Weight (kg)	Product Code
100	250	55	230	70	5.7	100263

Offsets

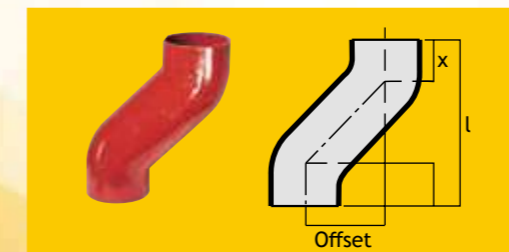

Pipe Dia (mm)	Offset	x (mm)	l (mm)	Nom Weight (kg)	Product Code
100	65	70	205	2.5	662864
100	130	70	270	3.4	662874
100	200	70	340	4.4	662884



Single Branches 45°

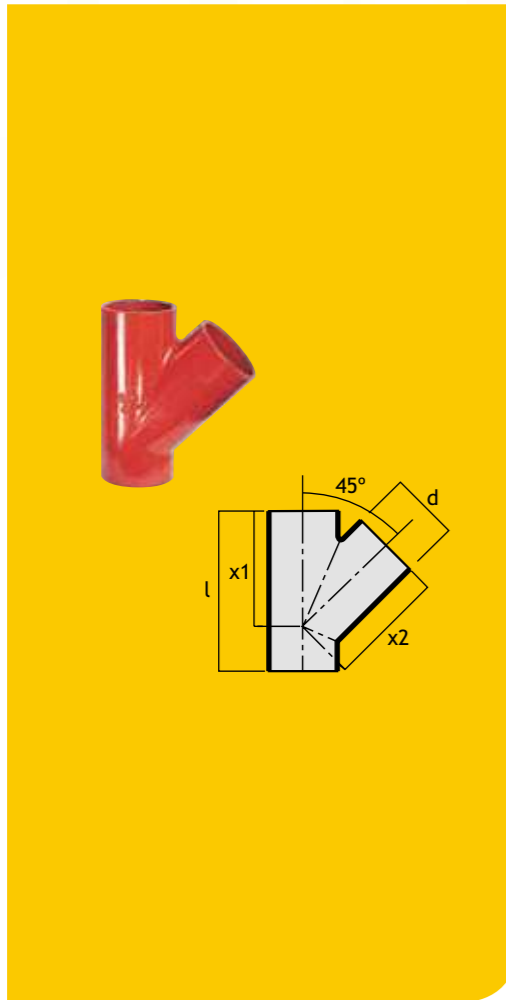

Pipe Dia (mm)	d (mm)	x1 (mm)	x2 (mm)	l (mm)	Nom Weight (kg)	Product Code
50	50	115	115	160	1.4	664004
70	50	130	130	170	1.6	663034
70	70	145	145	200	2.3	663064
100	50	150	150	180	2.5	663094
100	70	170	170	215	3.3	663124
100	100	190	190	260	4.2	663154
125	50	170	170	190	3.4	663184
125	70	185	185	225	4.3	663214
125	100	210	210	270	5.2	663244
125	125	230	230	305	6.4	663274
150	70	205	205	235	5.6	663334
150	100	225	225	280	6.8	663364
150	125	245	245	315	8.0	663394
150	150	265	265	355	9.2	663424
200	70	235	240	250	8.1	663484
200	100	260	260	300	10.0	663514
200	125	280	280	335	11.9	663544
200	150	300	300	375	12.4	663574
200	200	340	340	455	17.2	663604
250	100	305	305	320	15.4	663634
250	125	330	330	365	17.7	664504
250	150	350	350	405	20.4	664514
250	200	380	380	470	25.1	663644
250	250	430	430	560	31.5	663654
300	100	345	345	350	19.0	663664
300	125	360	360	375	22.2	664524
300	150	380	380	415	23.0	664534
300	200	415	440	485	34.0	664444
300	250	465	465	580	42.1	663674
300	300	505	505	660	50.1	663684
400*	300	555	565	660	60.0	663694

d = connecting branch dia
* 400mm dia single branch is available on request

Single Branches 68°

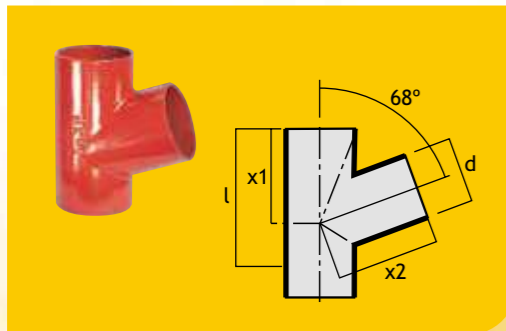

Pipe Dia (mm)	d (mm)	x1 (mm)	x2 (mm)	l (mm)	Nom Weight (kg)	Product Code
50	50	80	80	135	0.9	663014
70	50	90	90	140	1.2	663044*
70	70	100	100	170	1.6	663074
100	50	110	100	155	1.9	663104*
100	70	110	120	180	2.3	663134*
100	100	130	120	180	3.0	663164
125	50	110	120	165	2.7	663194*
125	100	140	145	225	4.8	663254
150	100	150	155	235	5.3	663374*

d = connecting branch dia
* obsolete

Single Branches 88°

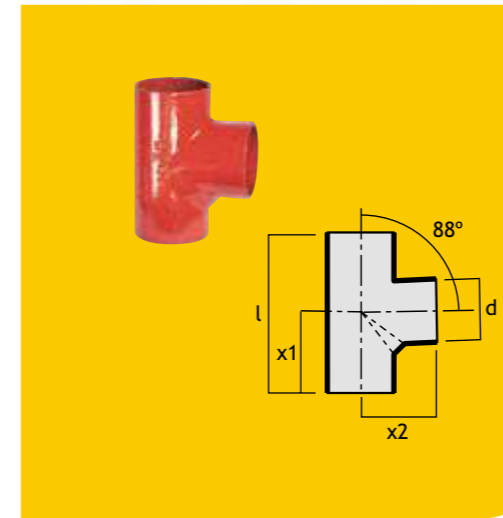

Pipe Dia (mm)	d (mm)	x1 (mm)	x2 (mm)	l (mm)	Nom Weight (kg)	Product Code
50	50	66	80	145	0.9	663024
70	50	72	90	155	1.4	663054
70	70	83	95	180	1.7	663084
100	50	76	105	170	2.1	663114
100	70	88	110	190	2.4	663144
100	100	105	115	220	2.9	663174*
125	50	82	120	180	3.0	663204
125	70	93	125	200	3.4	663234
125	100	110	130	235	4.0	663264
125	125	123	135	260	4.6	663294
150	50	100	140	200	4.4	663324
150	100	115	145	245	5.5	663384
150	125	128	150	275	6.2	663414
150	150	142	155	300	6.9	663444
200	200	205	210	380	10.1	234752

d = connecting branch dia
* Product code 663174 is available with a 250mm long spigot. When this is required specify code 664454

Double Branches 45°

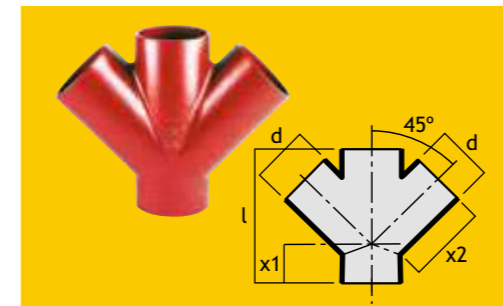

Pipe Dia (mm)	d (mm)	x1 (mm)	x2 (mm)	l (mm)	Nom Weight (kg)	Product Code
100	100	70	190	260	5.1	100260
125	100	60	220	280	6.5	237737
150	100	55	225	280	8.2	661444

d = connecting branch dia

Double Branches 68°

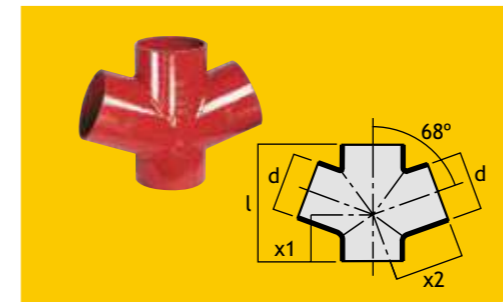

Pipe Dia (mm)	d (mm)	x1 (mm)	x2 (mm)	l (mm)	Nom Weight (kg)	Product Code
100	100	85	130	215	3.5	663864
125	100	85	145	225	5.0	663954

d = connecting branch dia

Double Branches 88°

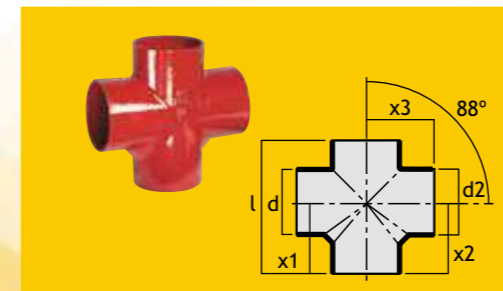

Pipe Dia (mm)	d (mm)	d2 (mm)	x1 (mm)	x2 (mm)	x3 (mm)	l (mm)	Nom Wt (kg)	Product Code
100	50	50	94	94	105	170	2.2	663814
100	70	70	102	102	110	190	2.7	663844
100	100	100	115	115	115	220	3.2	663874
150	100	70	130	112	145	245	6.0	664184
150	100	100	130	112	145	245	5.9	664084

d = connecting branch dia



Swept Double Branches 88°

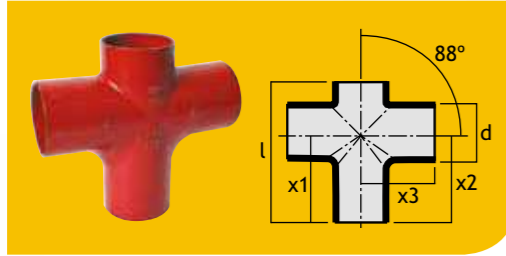

Pipe Dia (mm)	d (mm)	x1 (mm)	x2 (mm)	x3 (mm)	l (mm)	Nom Wt (kg)	Product Code
100	100	165	165	152	270	4.8	100264

d = connecting branch dia

Corner Branches 45°

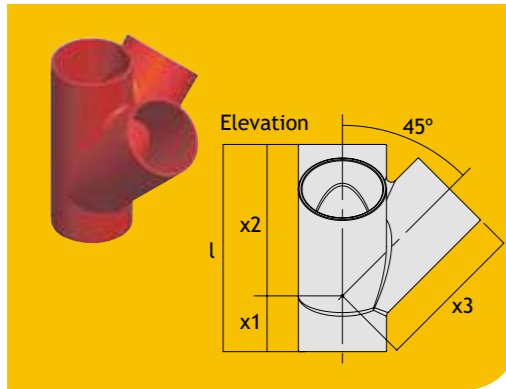

Pipe Dia (mm)	d (mm)	x1 (mm)	x2 (mm)	x3 (mm)	l (mm)	Nom Weight (kg)	Product Code
100	100	70	190	190	260	4.5	239702

d = connecting branch dia

Corner Branches 88°

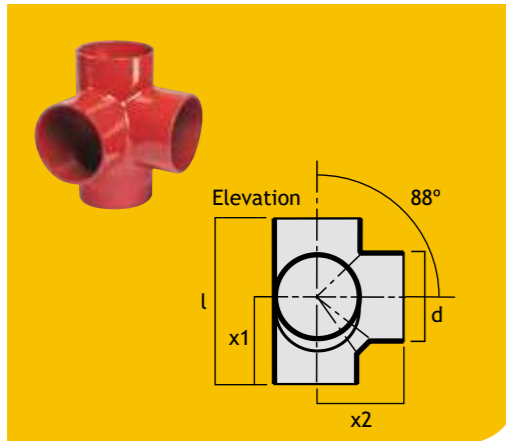

Pipe Dia (mm)	d (mm)	x1 (mm)	x2 (mm)	l (mm)	Nom Weight (kg)	Product Code
100	70	102	110	190	2.7	662044
100	100	115	115	220	3.4	662034*
125	100	125	130	235	4.6	662014
150	100	130	145	245	4.9	664434

d = connecting branch dia

* Product code 662034 is available with a 250mm long spigot. When this is required specify code 664464.

Combination Branches

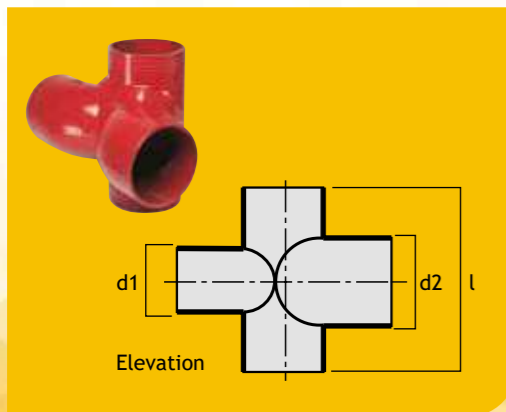

Pipe Dia (mm)	d1 (mm)	d2 (mm)	l (mm)	Nom Weight (kg)	Product Code
100	70	100	230	4.0	665834
100	100	100	230	5.0	665924

d = connecting branch dia



Round Access Pipes

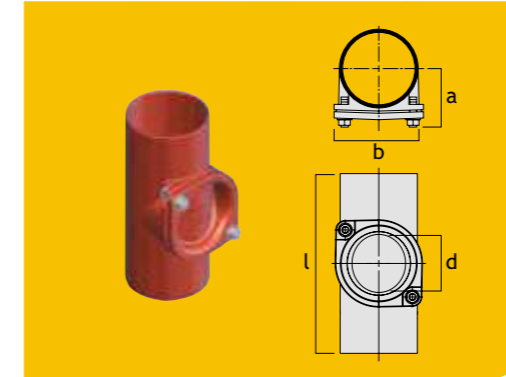

Pipe Dia (mm)	a (mm)	b (mm)	d (mm)	l (mm)	Access	Nom Wt (kg)	Product Code
50	58	90	53	190	4	1.8	669580
70	71	105	73	210	4	2.3	669583
100	82	125	104	260	4	3.8	669586

Rectangular Access Pipes

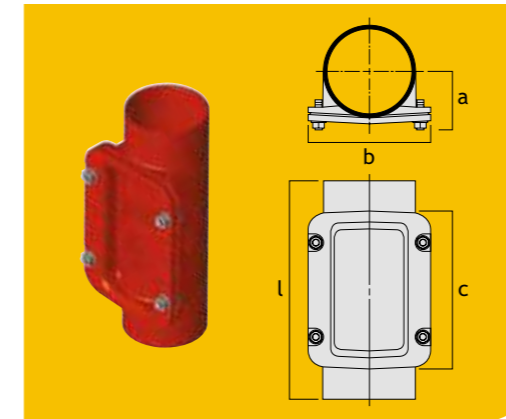

Pipe Dia (mm)	a (mm)	b (mm)	c (mm)	l (mm)	Access	Nom Wt (kg)	Product Code
100	82	160	230	340	4	6.0	669624
125	99	190	255	370	4	8.3	669627
150	112	215	280	395	4	12.0	669630
200	136	265	330	465	4	19.0	669633
250	165	330	383	540	4	31.0	669612
300	195	380	430	610	4	47.0	669615

Long and Short Access Bends 88°

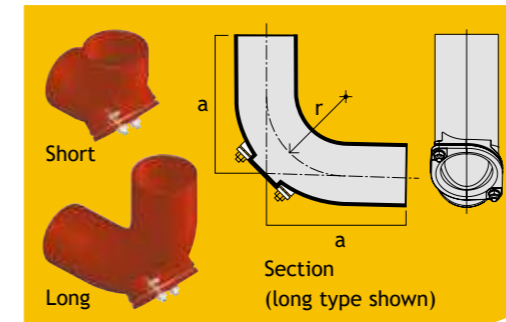

Pipe Dia (mm)	Type	a (mm)	r (mm)	Access	Nom Weight (kg)	Product Code
100	Short	110	—	4	3.3	661174A
150	Short	145	—	4	6.1	23274
100	Long	230	150	4	6.2	661174AL

Swept Entry Branches 88° – With and Without Access

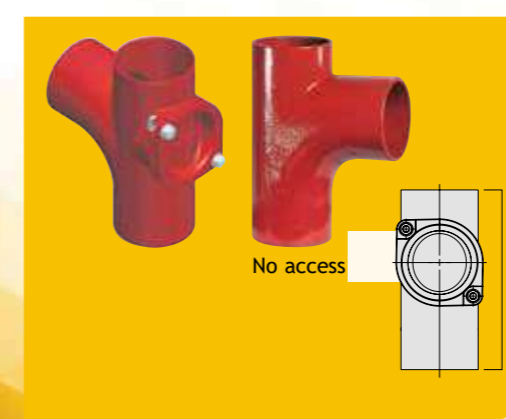

Pipe Dia (mm)	a (mm)	b (mm)	c (mm)	d (mm)	l (mm)	Access	Nom Wt (kg)	Product Code
100	168	102	150	100	270	6	4.2	6631745
100	168	102	150	100	270	4	4.5	6631745A
150	183	117	202	100	300	6	12.5	235684

Boss Pipes 88°

Pipe Dia (mm)	Boss Type	a (mm)	b (mm)	c (mm)	d (mm)	l (mm)	Nom Wt (kg)	Product Code
50	B	68	72	74	2" BSP	140	1.0	240581
70	B	71	74	74	2" BSP	145	1.2	663054B
100	B	75	75	75	2" BSP	150	1.9	663114B
100	DB	75	75	75	2" BSP	150	2.3	663114DB
100	CB	75	75	75	2" BSP	150	2.2	663114CB
150	B	88	88	104	2" BSP	175	3.8	232746
150	DB	88	88	104	2" BSP	175	4.8	237738

d = connecting branch dia

Reducers

Pipe Dia (mm)	a (mm)	l (mm)	Nom Weight (kg)	Product Code
70	50	75	0.5	662504
100	50	80	0.9	662514
125	50	85	1.4	662534
150	50	95	2.0	662564
100	70	85	0.9	662524
125	70	90	1.5	662544
150	70	100	2.1	662574
125	100	95	1.5	662554
150	100	105	2.2	662584
200	100	115	4.1	662604
150	125	110	2.2	662594
200	125	120	4.1	662614
200	150	125	4.3	662624
250	150	135	6.8	662634
300	150	150	9.7	662494
250	200	145	7.0	662644
300	200	160	11.4	662714
300	250	170	12.4	662724
400*	300	180	15.1	662444

*400mm dia pipe is available on request

Downpipe Supports

Pipe Dia (mm)	x (mm)	d (mm)	l (mm)	Nom Weight (kg)	Product Code
50	96	87	200	1.3	661544
70	96	106	200	1.6	661554
100	96	145	200	2.3	661564
125	96	170	200	3.3	661574
150	96	105	200	4.0	661584
200	96	245	200	7.2	661594
250	146	340	300	14.0	661604
300	146	390	300	25.7	661614

For use with Stack Pipe Support Bracket. (See pages 24 and 68-69 for details)

End Caps – Blank Ends

Pipe Dia (mm)	l (mm)	Nom Weight (kg)	Product Code
50	30	0.2	665504
70	35	0.4	665514
100	40	0.5	665524
125	45	1.1	665534
150	50	1.7	665544
200	60	3.1	665554
250	70	6.0	665564
300	80	9.5	665574
400*	82	17.0	665594

*on request

End Caps – Tapped

Pipe Dia (mm)	Tap Dia (mm)	l (mm)	Nom Weight (kg)	Product Code
50	40 (1 1/2")	30	0.2	665504TE
70	50 (2")	35	0.4	665514TE
100	50 (2")	40	0.5	665524TE
150	50 (2")	50	1.7	665544TE
200	50 (2")	60	3.1	665544TE

End Caps – Plug

Pipe Dia (mm)	a (mm)	b (mm)	d (mm)	d (mm)	e (mm)	Nom Wt (kg)	Product Code
100	179	122	86	24	25	1.3	664804
125	204	145	86	24	25	1.8	664814
150	200	-	85	24	25	2.7	664824
200	248	-	71	24	25	3.7	664834

Bearing Rings

Int Pipe Dia (mm)	a (mm)	b (mm)	c (mm)	d (mm)	Nom Weight (kg)	Product Code
50	193	25	33	61	0.8	666314
70	214	26	33	81.5	1.0	666324
100	250	28	33	115	1.3	666334
125	275	28	33	138	1.5	666344
150	301	30	33	163	2.0	666354
200	360	30	36	215	3.0	666374
250	442	34	40	280	5.6	227152
300	495	39	40	332	7.4	227153

Manifold Connectors

Pipe Dia (mm)	d (mm)	k (mm)	b (mm)	l (mm)	Nom Weight (kg)	Product Code
100	288	240	65	40	4.6	214089
150	288	270	65	60	5.2	240417

See page 73 for details

Sleeved Connectors

Pipe Dia (mm)	d (mm)	l (mm)	m (mm)	Nom Weight (kg)	Product Code
100	144	250	40	3.4	662194
125	172	250	42.5	4.6	662204
150	201	250	45	6.1	662214

Stoneware Connectors

Pipe Dia (mm)	d (mm)	l (mm)	m (mm)	Nom Weight (kg)	Product Code
100	159	140	70	4.9	664924
125	187	140	70	6.7	664934
150	218	140	70	9.7	664944
200	278	140	70	13.3	664954

Flanged Connectors

Pipe Dia (mm)	d (mm)	k (mm)	b (mm)	l (mm)	Nom Weight (kg)	Product Code
100	220	180	24	150	6.2	665934
125	250	210	26	150	8.4	665944
150	285	240	26	150	10.3	665954
200	340	295	26	150	14.5	665964

Pipe with Wall Flange

Pipe Dia (mm)	x1 (mm)	x2 (mm)	x3 (mm)	x4 (mm)	Nom Weight (kg)	Product Code
100	200	400	60	38	8.8	662224

Branch Traps

Pipe Dia (mm)	l (mm)	h (mm)	w (mm)	x1 (mm)	x2 (mm)	Nom Wt (kg)	Product Code
50	190	250	60	68	68	3.0	669562
70	265	293	60	93	93	5.0	669563
100	325	392	100	110	110	9.9	669564
125	390	446	100	130	130	13.0	669565
150	470	493	100	145	145	19.5	669566
200	600	608	100	180	200	36.5	669567

Plain Trap

Pipe Dia (mm)	l (mm)	h (mm)	x1 (mm)	x3 (mm)	Nom Weight (kg)	Product Code
100	370	297	80	55	7.3	100261

Rainwater Stench Traps

Pipe Dia (mm)	a (mm)	b (mm)	c (mm)	l (mm)	Nom Weight (kg)	Product Code
70	195	90	80	472	9.0	669557
100	276	124	90	588	18.5	669558
125	344	144	100	687	28.5	669559
150	374	179	110	742	38.0	669560

Konfix Single (Waste adaptor)

Pipe Dia (mm)	d1 (mm)	d2 (mm)	d3 (mm)	d4 (mm)	d5 (mm)	d6 (mm)	l (mm)	Product Code
50	72	56	48	40	57	66.5	58	100270
70	92	75	63	56	77	85.5	73	100271
100	128	108	104	—	108	116	102.5	100272

Konfix Multi (Waste adaptor)

Pipe Dia (mm)	d1 (mm)	d2 (mm)	d3 (mm)	d4 (mm)	d5 (mm)	d6 (mm)	l (mm)	Product Code
100	134	—	—	—	108	116	90.5	100030

Harmer Duomat Fixing Tool

Description	Product Code
Harmer Duomat Fixing Tool – 7-10 Nm torque setting	3900
For use with Stainless Steel Couplings: Duo and Grip See pages 59 and 61	

1/2" Drive Tools

Description	For Use With	Product Code
Ratchet Handle 1/2" Drive	For use with 1/2" Drive	110000
Torque Wrench 1/2" Drive: 20 Nm - 40 Nm torque	Couplings with 20 Nm - 40 Nm torque range	110001
10mm 1/2" Drive Socket	Harmer Optimal Bracket	110007
13mm 1/2" Drive Socket	70, 100, 150mm Access Bends, Swept Entry Branches, End Caps, Branch Traps	110002
18mm 1/2" Drive Socket	150mm Access Pipe Rectangular Door, Branch Trap	110003
19mm 1/2" Drive Socket	All pipe sealing flanges	110004
5mm Allen Key 1/2" Drive Socket	Stainless Steel Couplings	110008
6mm Allen Key 1/2" Drive Socket	Ductile Iron Couplings, 50mm Axilock S Coupling	110005
8mm Allen Key 1/2" Drive Socket	70, 100mm Axilock S Coupling	110013
10mm Allen Key 1/2" Drive Socket	125, 150mm Axilock S Coupling	110012
14mm Allen Key 1/2" Drive Socket	200, 250, 300, 400mm Axilock S Coupling	110014
10mm Flat Bit with 3/8" Hexagonal Shank	General purposes	110006

See pages 59 and 61 for further details

3/8" Drive Tools

Description	Product Code
Torque Wrench 3/8" Drive - 4Nm – 20Nm torque	Couplings with 4 Nm - 20 Nm torque range
5mm Allen Key 3/8" Drive Socket	Stainless Steel Couplings
6mm Allen Key 3/8" Drive Socket	Ductile Iron Couplings

See pages 59 and 61 for further details

Harmer SML Touch Up Paint

Description	Product Code
Harmer SML Touch Up Paint 1 litre	TUP/RAL3009M

Harmer SML Below Ground Range

The Below Ground range is part of the cast iron, dry-jointed pipework system complete with a comprehensive suite of fittings and accessories. Fully compatible with the Above Ground range.

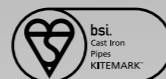

BIM available



Below Ground - Product Range Summary

All Harmer SML pipes and fittings comply with BS EN 877, being manufactured under strict factory-controlled conditions to meet the highest performance standards. They are durable, recyclable, quick and easy to install and require low maintenance.

Pipes

Harmer SML pipes are available in standard 3m lengths, in diameters of 100mm to 400mm, providing everything for high performance, lightweight cast iron soil and waste systems. Pipes have an exterior primer coating, minimum thickness 40 µm. The interior of pipes has an epoxy coating with a minimum thickness of 120 µm. See page 41.

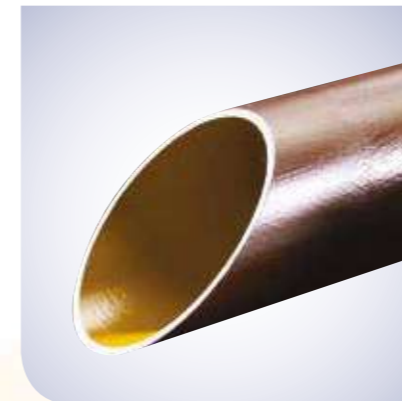

Branches

Fittings designed to accommodate connection of branch pipework to a principal horizontal pipe run. The available range includes single and double branches. They are coated externally and internally with an epoxy coating, minimum thickness 60µm. See page 43.



Bends

A wide range of bends to accommodate change of direction, meeting a wide variety of design requirements, including single bends, long radius bends, bends with spigots, and rest bends. They are coated externally and internally with an epoxy coating, minimum thickness 60µm. See page 42.



Access Fittings

Designed to allow access for inspection and rodding – includes circular access pipes, rectangular access pipes, access bends and branches. They are coated externally and internally with an epoxy coating, minimum thickness 60µm. See page 44.



Couplings

Harmer SML couplings are specially designed for joining lengths of Harmer SML pipe, and for joints between pipes and fittings. Couplings are available in stainless steel and ductile iron. Like Harmer SML pipes and fittings, all Harmer SML couplings have been subject to rigorous testing and meet the requirements of BS EN 877. See page 41.



Inspection Chambers and Associated Fittings

Round, square and rectangular inspection chambers are available complete with bellmouth gully, solid plate and grate. See page 46.fi



Completing the Product Range

The range also includes bracketry, end caps, reducers, puddle flanges, trap, and fixing tools.

See pages 41, 45 and 47.

technical@alumascwms.co.uk



The complete range of Harmer SML pipes, pipe fittings, pipe couplings and pipe brackets will be found in the following list of product tables.



Pipes

All diameters in 3000mm lengths	41
---------------------------------	----

Pipe Couplings

Adaptor	41
Ductile Iron	41
Stainless Steel Duo	41

Pipe Brackets

Ductile Iron	41
--------------	----

Pipe Fittings (Bends)

Single Bends 15°	42
Single Bends 30°	42
Single Bends 45°	42
Long/Medium Radius Bends 22°, 45°, 88°	42
Rest Bends	42

Pipe Fittings (Branches)

Single Branches 45°	43
Single Branches 88°	43
Double Branches 45°	43
Double Branch 68°	43
Double Branch 88°	43

Pipe Fittings (Access)

Long Access Bend 88°	44
Swept Entry Branch With Access 88°	44
Round Access Pipe	44
Rectangular Access Pipes	44
Rodding Access	44

Pipe Fittings (Miscellaneous)

Reducers	45
Blank End Caps	45
Plain Trap	45
Puddle Flanges	45

Pipe Fittings (Chambers)

Round Inspection Chambers	46
Square Inspection Chambers	46
Rectangular Inspection Chambers	46

Pipe Fittings (Bellmouth Items)

Gully	46
Solid Plate	46
Grate	46

Fixing Tools/Touch Up Paint

Harmer Duomat Tool	47
1/2" Drive Tools	47
3/8" Drive Tools	47
Touch Up Paint	47



Pipes

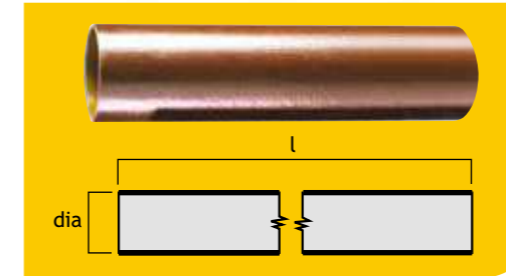

Pipe Dia (mm)	Pipe O/D (mm)	l (mm)	Nom Weight (kg)	Product Code
100	110	3000	25.6	232055
150	150	3000	42.8	232057
200	210	3000	71.5	232058
250	274	3000	91.0	232095
300	326	3000	125.2	232097
400	429	3000	175.5	232100

Ductile Iron Couplings

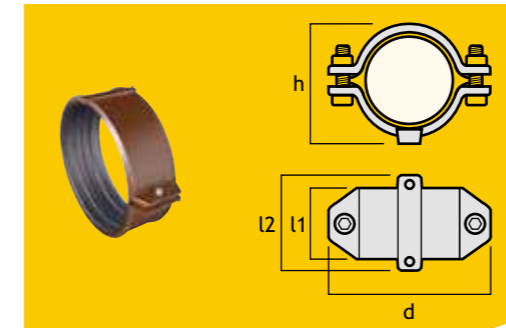

Pipe Dia (mm)	h (mm)	d (mm)	l1 (mm)	l2 (mm)	Nom Weight (kg)	Product Code
100	134	168	60	78	1.1	235359
150	184	230	71	89	1.9	235362
200	231	278	82	100	3.5	235363

Stainless Steel Duo Couplings

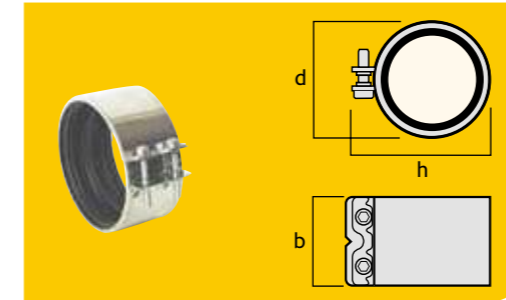

Pipe Dia (mm)	Bolts	d (mm)	h (mm)	b (mm)	Product Code
100	2	125	140	55	3140/100
150	2	175	190	70	3140/150
200	4	220	255	70	3140/200
250	8	280	315	140	3140/250
300	8	335	370	140	3140/300

400mm coupling available on request

Adaptor Couplings

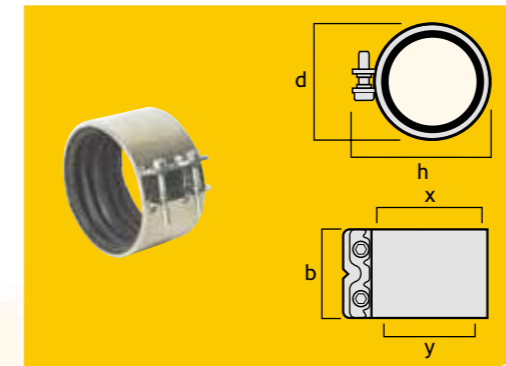

Pipe Dia (mm)	Bolts	d (mm)	h (mm)	b (mm)	x (mm)	y (mm)	Product Code
70*	2	95	110	70	83-84	75-76	3151/070075
100**	2	130	145	70	116-119	108-113	3102/100
150**	4	180	215	70	168	158-162	3102/150

Adapts lightweight 'soil' to conventional 'drain'.

*Connection of 3" SML to 3" Harmer/Wade roof outlets.

**Connection of SML EN 877 to BS 437 pipe.

Ductile Iron Brackets (For Vertical and Horizontal Pipework Applications)

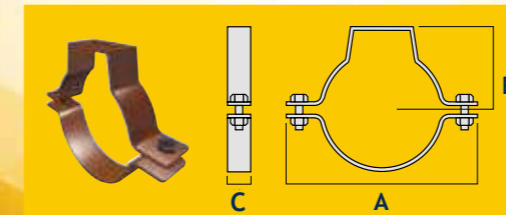

Pipe Dia (mm)	a (mm)	b (mm)	c (mm)	Nom Wt (kg)	Product Code
100	28	88	167	0.6	DB100BG
150	30.5	114	216	0.85	DB150BG
200	30.5	148	267	1.6	DB200BG



Single Bends 15°

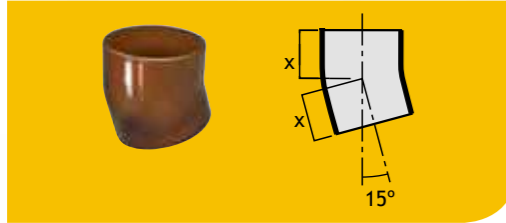

Pipe Dia (mm)	x (mm)	Nom Weight (kg)	Product Code
100	50	1.0	232059
150	65	2.5	232065

Single Bends 30°

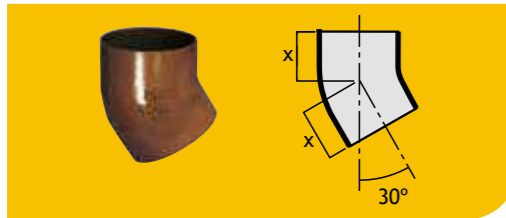

Pipe Dia (mm)	x (mm)	Nom Weight (kg)	Product Code
100	60	1.3	232060
150	80	3.1	232066

Single Bends 45°



Pipe Dia (mm)	x (mm)	Nom Weight (kg)	Product Code
100	70	1.5	232061
150	90	3.5	232067
200	110	5.5	232070
250	130	10.3	232103
300	155	17.0	232104

Long and Medium Radius Bends 22.5°, 45° and 88°

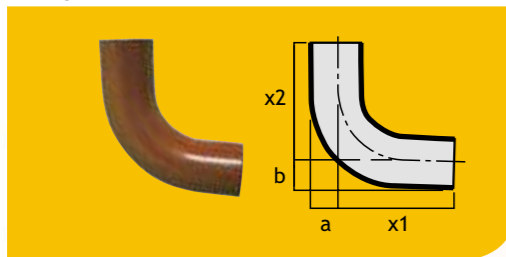

Pipe Dia (mm)	Angle (degree)	x1 (mm)	a (mm)	x2 (mm)	b (mm)	Nom Weight (kg)	Product Code
100*	88	255	55	255	55	5.1	232105
100**	22.5	88.5	55	119	55	2.37	23210022
100**	45	67	55	196	55	3.45	23210045
150**	88	250	80	250	80	7.8	232106
150**	45	49.5	80	221.5	80	5.09	23215045

* Long radius bend **Medium radius bend

Rest Bends

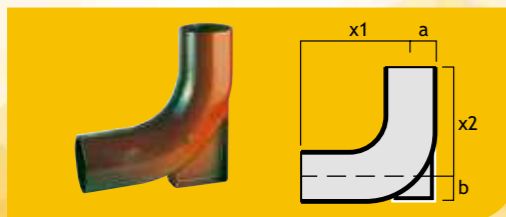

Pipe Dia (mm)	x1	a	x2	b	Nom Weight (kg)	Product Code
100	260	55	251	56	5.7	232110
150	278	80	276	18	8.9	232150



Single Branches 45°

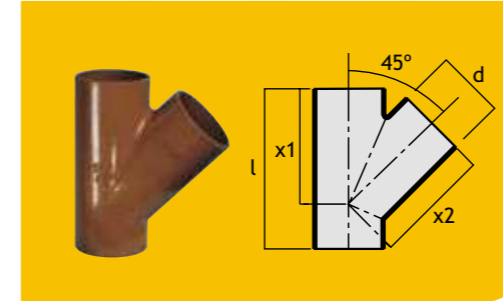

Pipe Dia (mm)	d (mm)	x1 (mm)	x2 (mm)	l (mm)	Nom Weight (kg)	Product Code
100	100	190	190	260	4.2	232077
150	100	225	225	280	6.8	232080
150	150	265	265	355	9.2	232082
200	100	260	260	300	10.0	232083
200	150	300	300	375	12.4	232085
200	200	340	340	455	17.2	232086
250	250	430	430	560	31.5	232111
300	300	505	505	660	50.1	232112

d = connecting branch dia

Single Branches 88°

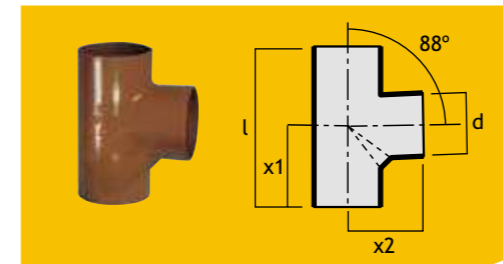

Pipe Dia (mm)	d (mm)	x1 (mm)	x2 (mm)	l (mm)	Nom Weight (kg)	Product Code
100	100	105	115	220	2.9	232113
150	100	115	145	245	5.5	232114
150	150	142	155	300	6.9	232115

d = connecting branch dia

Double Branches 45°

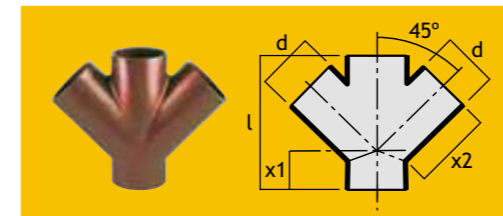

Pipe Dia (mm)	d (mm)	x1 (mm)	x2 (mm)	l (mm)	Nom Weight (kg)	Product Code
100	100	70	190	260	5.1	232117
150	100	55	225	280	8.2	232118

d = connecting branch dia

Double Branch 68°

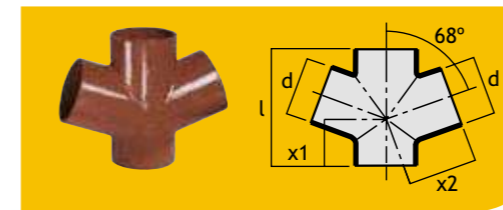

Pipe Dia (mm)	d (mm)	x1 (mm)	x2 (mm)	l (mm)	Nom Weight (kg)	Product Code
100	100	85	130	215	3.5	232116

d = connecting branch dia

Double Branch 88°

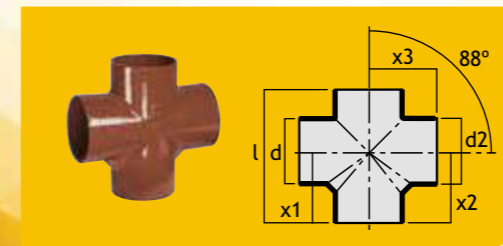

Pipe Dia (mm)	d (mm)	d2 (mm)	x1 (mm)	x2 (mm)	x3 (mm)	l (mm)	Nom Wt (kg)	Product Code
100	100	100	115	115	115	220	3.2	232119

d = connecting branch dia



Long Access Bend 88°

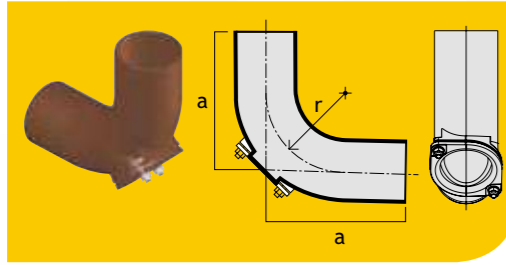

Pipe Dia (mm)	Type	a (mm)	r (mm)	Access	Nom Weight (kg)	Product Code
100	Long	230	150	4	6.2	232109

Swept Entry Branch 88° – With Access

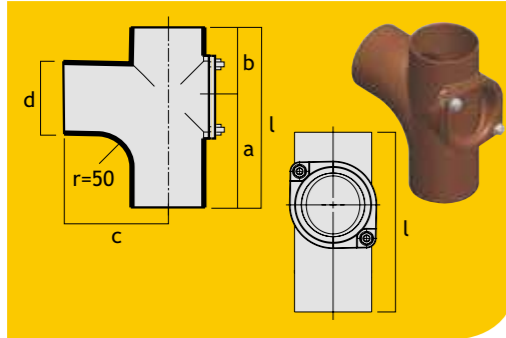

Pipe Dia (mm)	a (mm)	b (mm)	c (mm)	d (mm)	l (mm)	Access	Nom Wt (kg)	Product Code
100	168	102	150	100	270	6	4.5	232131

Round Access Pipe

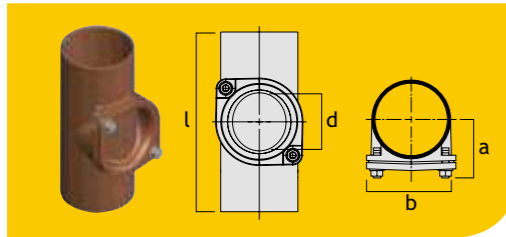

Pipe Dia (mm)	a (mm)	b (mm)	d (mm)	l (mm)	Access	Nom Wt (kg)	Product Code
100	84	159	104	250	4	3.8	232134

Rectangular Access Pipes

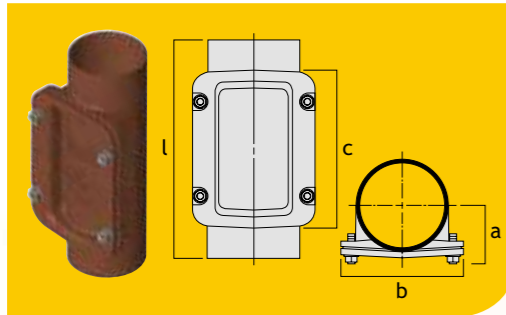

Pipe Dia (mm)	a (mm)	b (mm)	d (mm)	l (mm)	Access	Nom Wt (kg)	Product Code
100	83	160	230	320	4	7.6	232096
150	112	215	280	395	4	13.0	232099
200	137	262	330	465	4	22.0	232101
250	170	330	380	540	4	35.7	232137
300	195	380	430	610	4	51.0	232140

Rodding Access

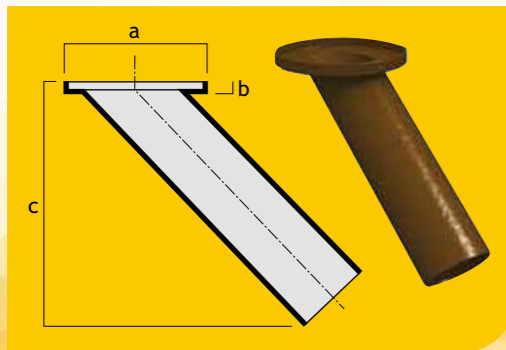

Pipe Dia (mm)	Angle (degree)	a (mm)	b (mm)	c	Nom Weight (kg)	Product Code
100	45	212	20.5	334.5	6.0	212100CA

Bellmouth Solid Plate or Grate to complete the assembly to be ordered separately. See page 46.

Reducers

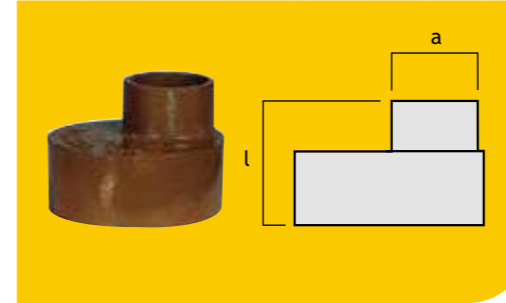

Pipe Dia (mm)	a (mm)	l (mm)	Nom Weight (kg)	Product Code
150	100	105	2.2	232072
200	100	115	4.1	232074
200	150	125	4.3	232076
250	150	135	6.8	232120
250	200	145	7.0	232121
300	150	150	9.7	232122
300	200	160	11.4	232123
300	250	170	12.4	232124

Blank End Caps

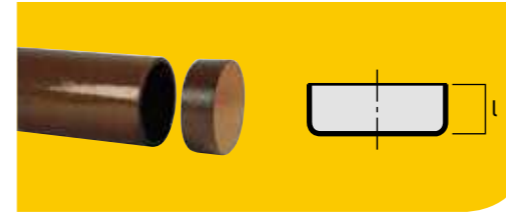

Pipe Dia (mm)	l (mm)	Nom Weight (kg)	Product Code
100	40	0.5	232091
150	50	1.7	232093
200	60	3.1	232094
250	70	6.0	232126
300	80	9.5	232127

Plain Trap

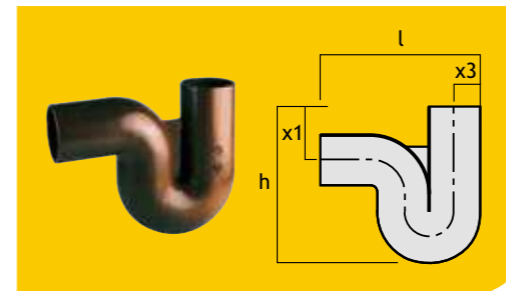

Pipe Dia (mm)	l (mm)	h (mm)	x1 (mm)	x3 (mm)	Nom Weight (kg)	Product Code
100	370	297	80	55	8.0	232125

Puddle Flanges

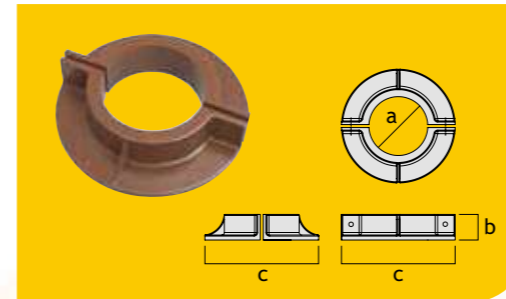

For Pipe Dia (mm)	a (mm)	b (mm)	c (mm)	Nom Weight (kg)	Product Code
100	115	50	222	4.0	PF100
150	162	50	273	6.0	PF150



Round Inspection Chambers

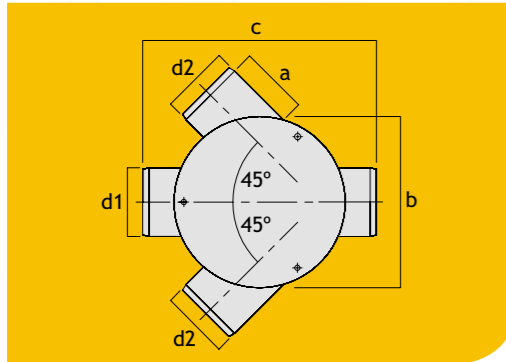

Int Pipe Dia (mm)	a (mm)	b (mm)	c (mm)	d1 (mm)	d2 (mm)	Nom Wt (kg)	Product Code
100	110	274	374	110	110	16	GCSR/100100
150	110	274	394	160	110	18	GCSR/150100
150	199	274	393	160	160	24	GCSR/150150

d2 = connecting branch outside dia



Square Inspection Chambers

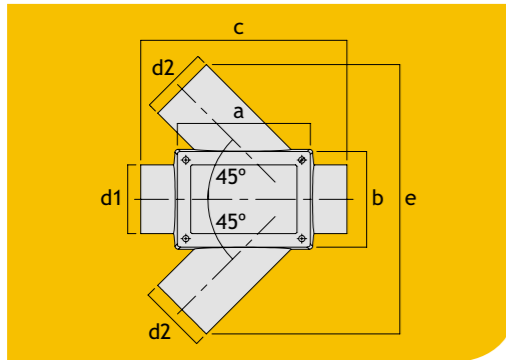

Int Pipe Dia (mm)	a (mm)	b (mm)	c (mm)	d1 (mm)	d2 (mm)	e (mm)	Nom Wt (kg)	Product Code
100	213	153	330	110	110	431	14	SSC100100
150	210	200	350	160	110	487	17	SSC150100
150	256	202	420	160	160	577	24	SSC150150

d2 = connecting branch outside dia



Rectangular Inspection Chambers

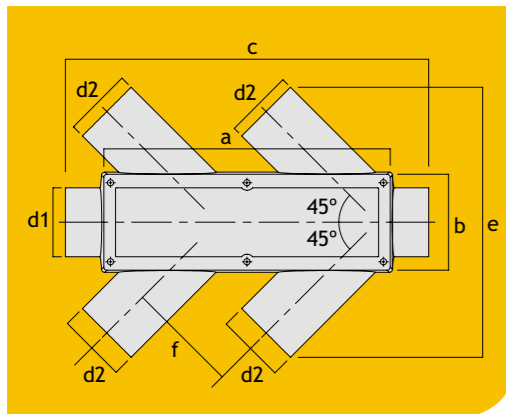

Int Pipe Dia (mm)	a (mm)	b (mm)	c (mm)	d1 (mm)	d2 (mm)	e (mm)	f (mm)	Nom Wt (kg)	Product Code
100	457	153	480	110	110	431	180	27	DRC100100
150	457	203	600	160	110	487	178	32	DRC150100
150	626	201	765	160	160	577	252	43	DRC150150

d2 = connecting branch outside dia



Bellmouth Gully

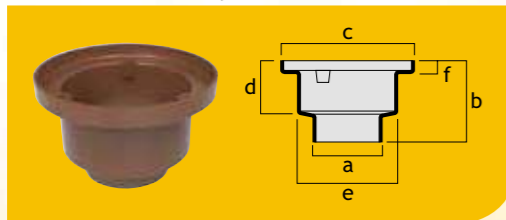

Int Pipe Dia (mm)	a (mm)	b (mm)	c (mm)	d (mm)	e (mm)	f (mm)	Nom Wt (kg)	Product Code
100-150	110	130	212	83	160	21	2.9	BG150

Multi-use gully for either 100 or 150mm connections

Bellmouth Solid Plate and Grate

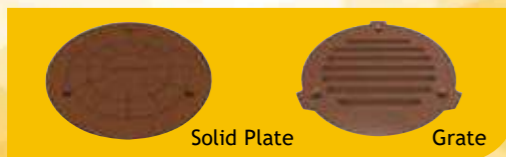

Type	Dia (mm)	Depth (mm)	Nom Wt (kg)	Product Code
Solid Plate	200	14	2.0	BMSP200
Grate	200	15	1.7	BMG200



Harmer Duomat Fixing Tool

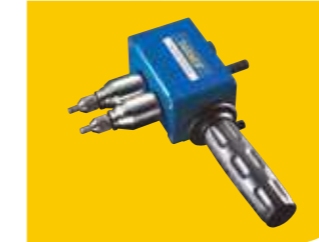

Description	Product Code
Harmer Duomat Fixing Tool – 7-10 Nm torque setting	3900
For use with Stainless Steel Couplings: Duo and Grip See pages 59 and 61	

1/2" Drive Tools



Description	For Use With	Product Code
Ratchet Handle 1/2" Drive	For use with 1/2" Drive	110000
Torque Wrench 1/2" Drive: 20 Nm - 40 Nm torque	Couplings with 20 Nm - 40 Nm torque range	110001
10mm 1/2" Drive Socket	Harmer Optimal Bracket	110007
13mm 1/2" Drive Socket	70, 100, 150mm Access Bends, Swept Entry Branches, End Caps, Branch Traps	110002
18mm 1/2" Drive Socket	150mm Access Pipe Rectangular Door, Branch Trap	110003
19mm 1/2" Drive Socket	All pipe sealing flanges	110004
5mm Allen Key 1/2" Drive Socket	Stainless Steel Couplings	110008
6mm Allen Key 1/2" Drive Socket	Ductile Iron Couplings, 50mm Axilock S Coupling	110005
8mm Allen Key 1/2" Drive Socket	70, 100mm Axilock S Coupling	110013
10mm Allen Key 1/2" Drive Socket	125, 150mm Axilock S Coupling	110012
14mm Allen Key 1/2" Drive Socket	200, 250, 300, 400mm Axilock S Coupling	110014
10mm Flat Bit with 3/8" Hexagonal Shank	General purposes	110006

See pages 59 and 61 for further details

3/8" Drive Tools



Description	Product Code
Torque Wrench 3/8" Drive - 4Nm – 20Nm torque	Couplings with 4 Nm - 20 Nm torque range
5mm Allen Key 3/8" Drive Socket	Stainless Steel Couplings
6mm Allen Key 3/8" Drive Socket	Ductile Iron Couplings

See pages 59 and 61 for further details

Harmer SML Touch Up Paint

Description	Product Code
Harmer SML Touch Up Paint 1 litre	TUP/RAL3009/SML

Harmer SML Technical Data

The Above and Below Ground drainage system is robust and complies with all relevant and appropriate building industry standards, guaranteeing long-term performance.

BIM available



Usage & Performance

Quality Standard

Harmer SML meets the requirements of BS EN 877 and is manufactured under ISO 9001: 2000 Quality Management System (Certificate No.12 100 21864), and is approved under the British Board of Agrément (BBA Certificate No. 05/4191)

Cast Iron Material

Harmer SML drainage pipe systems are manufactured from grey cast iron according to EN 1561 to a minimum material grade of EN-GJL-150 (EN-JL1020).

Protective Coatings

Soil and drainage pipe systems have to perform under extremely demanding conditions with domestic effluents containing aggressive cleaning agents and chemicals. The high-quality coating of Harmer SML goes beyond the requirements of BS EN 877. (See chemical resistance table below.)

Harmer SML drainage pipes are externally protected with anti-corrosive primer coating, which meets fire classification A1. On the inside the pipes are coated with two-part epoxy coating which offers high resistance against chemical and mechanical damage.

Coatings for Pipe and Fittings

Product		Coating Type		Average Thickness (µm)
		Above Ground	Below Ground	
Pipe	external	red primer coating	two-part brown & zinc base coating	40
	internal	two-part ochre epoxy	two-part ochre epoxy	120
Fittings	external	two-part red epoxy	two-part brown epoxy	60
	internal	two-part red epoxy	two-part brown epoxy	60

Specification

Harmer SML above-ground pipe as RAL 3009 oxide red external coating with fully cross-linked epoxy ochre internal coating. SML fittings dip applied as RAL 3009 oxide red internally and externally. Harmer SML below-ground as RAL 8011 nut brown external coating with fully cross-linked epoxy ochre internal coating. Additional thermal spray zinc coating to a minimum 130g/m² applied prior to top coat. SML below-ground fittings dip-applied as RAL 8011 nut brown internally and externally.

Other Applicable Standards

BS EN 12056: Gravity Drainage Systems Inside Buildings.
BS EN 752: Drainage and Sewer Systems Outside Buildings.
BS EN 1610: Construction and testing of drains and sewers.

Chemical Resistance of Interior Coatings of SML Pipes

Liquid	Up to 23°C	Up to 50°C	Up to 80°C
Acidic solutions	pH 0	BS EN 877	BS EN 877
	pH 1 (except organic acids)		
	pH 2 (except organic acids)		
	Lime-dissolving substances		
	Cleaning products		
	Detergents		
	Disinfectants		
	Stain removers		
	Oxidants		
	Water (pH 7), salts		
Alkaline solutions	Drain clearing products	BS EN 877	BS EN 877
	Solvents		
	pH 12		
	pH 13		
	pH 14		

Conditions where interior coatings meet chemical resistance requirements of BS EN 877

Conditions where interior coatings exceed chemical resistance requirements of BS EN 877

This table applies to applications with intermittent use.

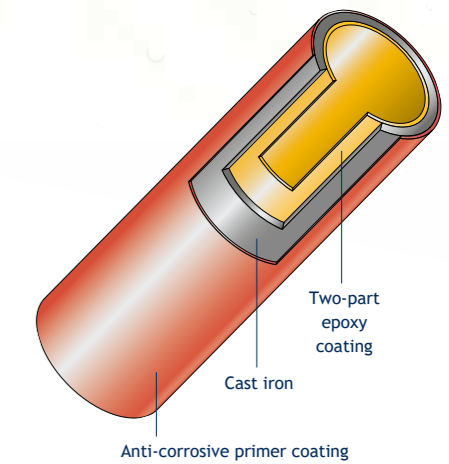

Above-Ground Pipe Coatings

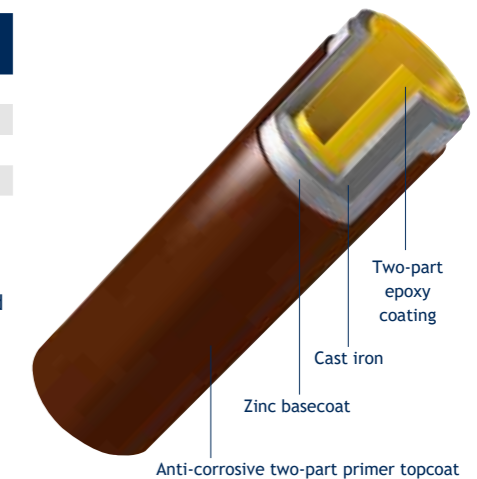

Below-Ground Pipe Coatings

Below-Ground Risk Factors

UV light degradation and the effect of mechanical damage are key factors in material selection. Cast iron provides key resistance benefits compared to other materials in below-ground pipe applications.

Hazard	Clay	Plastic	Cast Iron
Settlement	High Risk	Medium Risk	Low Risk
Shear Pressure	High Risk	Low Risk	Low Risk
Rodding Damage	Medium Risk	High Risk	Low Risk

Cast Iron Soil & Waste pipe systems offer a greater resistance to natural ground movement and less likely to fail in unfavourable ground conditions.

Other drainage materials need additional pipe protection in areas where ground disturbance or extra loading is likely, for example a covering concrete slab. No additional protection is required in most circumstances for a Cast Iron system.

Pipe Weights and Dimensional Tolerances

Nominal Pipe Dia (mm)	External Dia		Wall Thickness Min	Sealing Zone Min	Pipe Weight (kg/m)	
	Min	Max			Empty	Filled
50	57	60	3.0	30	5.3	7.3
70	77	80	3.0	35	6.2	10.2
100	109	112	3.0	40	8.5	16.8
125	133	137	3.5	45	11.7	24.4
150	158	162	3.5	50	14.3	32.5
200	208	212	4.0	60	23.8	55.3
250	271.5	276.5	4.5	70	30.3	84.6
300	323.5	328.5	5.0	80	41.7	119.1
400	426	431	5.0	80	58.5	194.7

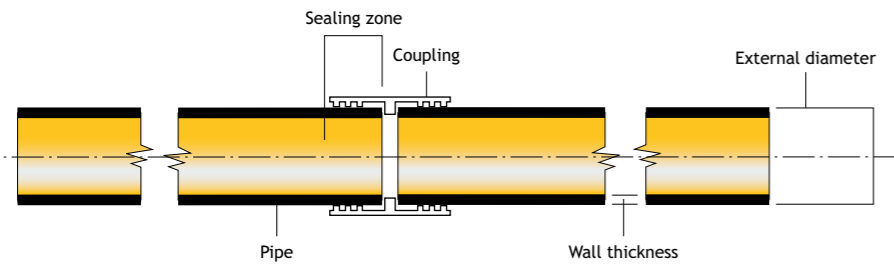

Product Identification

SML pipes and fittings are labelled during manufacture in accordance with the standard BS EN 877 and can be clearly identified as indicated below.

Pipe marks

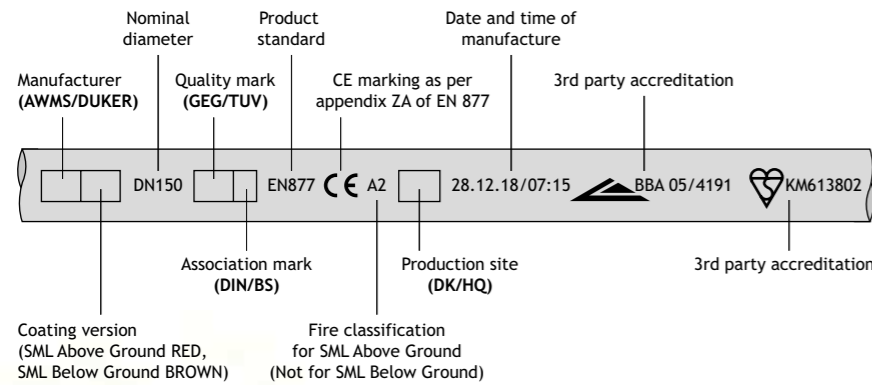

Fitting marks (both sides)

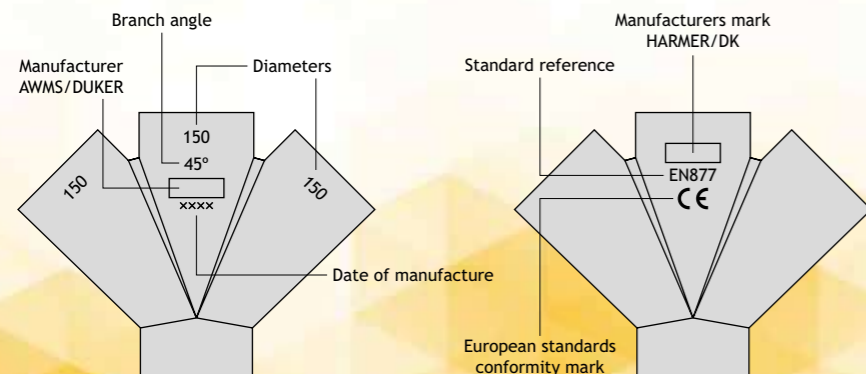

Tolerance Definitions

Weights

BS EN 877 stipulates: "The nominal masses of finished products (pipes, fittings and accessories) shall be given in the manufacturers' catalogues. When measured in accordance with Table 5.3 of the standard, the lower deviation shall not exceed 15% of the nominal mass".

Lengths

In accordance with clause 4.2.9 of BS EN 877, lengths of fittings shall be within a tolerance of ±5mm. Lengths of pipes shall be within a tolerance of ±20mm when measured in accordance with clause 5.2.7 of the standard.

Sealing zone

Ovality of pipes and the sealing zone of fittings shall remain within the tolerance of the external diameter.

Flow Capacities of Soil and Waste Systems

Maximum flow capacities (litres per second) of SML pipes, flowing at various gradients, with pipes flowing full (ks value = 0.6).

Pipe Dia (mm)	1:40 (l/s)	1:60 (l/s)	1:80 (l/s)	1:100 (l/s)
50	1.46	1.19	1.03	0.92
70	4.29	3.50	3.03	2.71
100	9.24	7.55	6.54	5.50
125	16.8	13.7	11.9	10.6
150	27.3	22.3	19.3	17.2
200	58.7	47.9	41.5	37.1
250	106.0	86.9	75.2	67.3
300	173.0	141.0	122.0	109.0
400	416.7	339.9	294.1	262.82

System design may limit soil and waste flow rates below these values. Higher flow rates will be possible for rainwater pipework.

For vertical flow capacities refer to BS EN 12056: 2000, Parts 2 and 3.



SML – above ground system

SML – below ground system

Introduction

The discharge of soil, waste and rainwater through a pipe generates structure-borne and airborne sound between habitable spaces and usually occurs because the pipe is filled with a mixture of air and water. The resultant noise will then be transmitted to lightweight ceilings, cupboards and similar constructions.

Cast iron pipe systems however, because of the high mass per unit area of their pipe walls as well as the joint design characteristics, provide considerable noise reduction benefits when discharging soil, waste and rainwater within buildings.

Testing and Certification

BS EN 14366: 2005-02: *Laboratory measurement of noise from waste water installations* sets out a common test method by which structure-borne and airborne noise emitted by installed discharge systems is measured. Harmer SML has been independently tested to this new standard as certified by the Fraunhofer Institute of Building Physics – test report P-BA 164/2008e and P-BA 165/2008e. See table below.

BS 8233: *Code of Practice for Sound Insulation and Noise Reduction for Buildings*, provides guidelines for indoor ambient noise levels for various room uses. The general requirement for residential/habitable rooms is 30-35 dB; the lowest design range is 20-25 dB for recording studios. The Harmer SML system is able to meet these low levels of acoustic performance.

Test Data

Pipe and Bracket Type (see drawing)	Airborne Sound Pressure Level $L_{a,A}$ [dB(A)] (see note a)				Structure-borne Sound Characteristic Level $L_{s,C,A}$ [dB(A)] (see note b)				Number of Brackets Used	Wall Density (kg/m ²)
	Flow rate	0.5 l/s	1.0 l/s	2.0 l/s	4.0 l/s	0.5 l/s	1.0 l/s	2.0 l/s		
1. Harmer SML with Optimal rubber-lined brackets	–	–	45	48	–	–	22	27	2	220
2. Harmer SML with Optimal rubber-lined brackets and spacers	39	43	45	48	9	14	19	24	2	220
3. Harmer SML with Optimal rubber-lined brackets with acoustic dampener (dB Fix) and Wall Plate	38	43	44	48	5	9	10	11	2	220

(a) Lower floor: front (b) Lower floor: rear

At 2.0 l/s - this corresponds more or less to a toilet flush. Using with optimum fixing technology is below 10 dB(A), that is, quieter than falling snow!

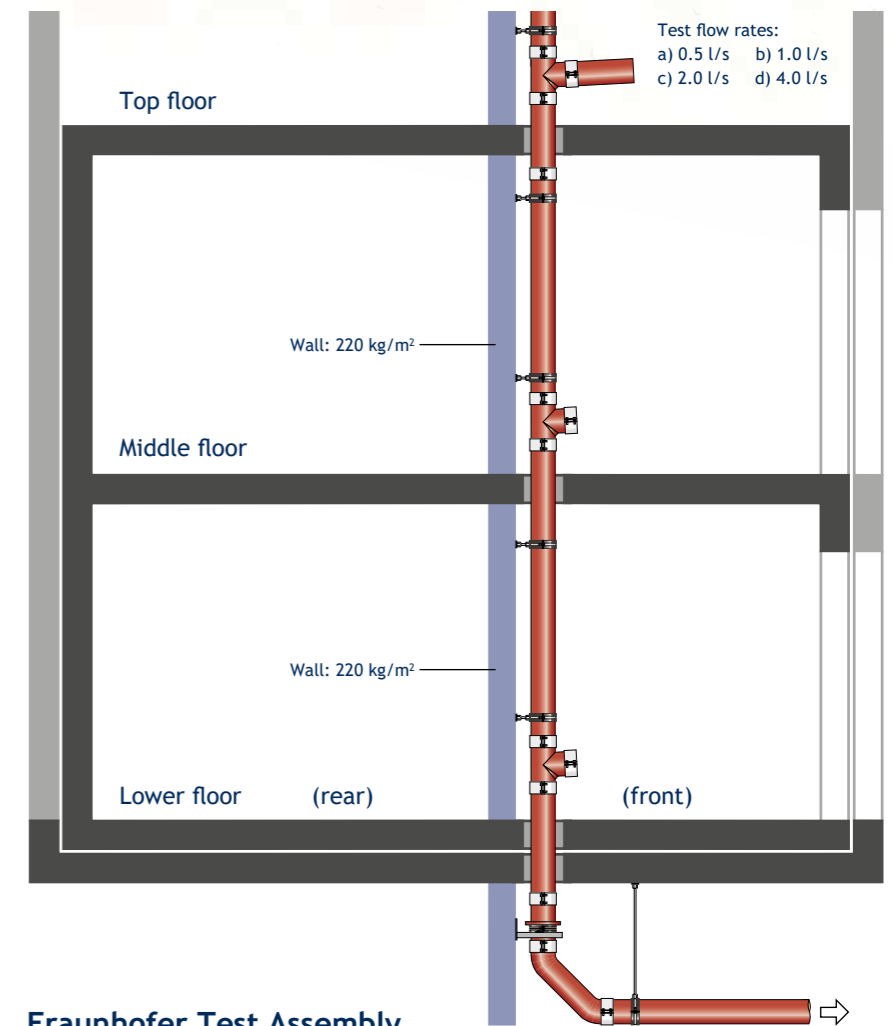

Fraunhofer Test Assembly

The Fraunhofer Institute of Building Physics test facility is constructed to a 220 kg/m² wall density. One of the most important parameters in the context of structure-borne sound is wall density, as changes can greatly affect the installation sound level. For example, a wall density reduced to 140 kg/m² gives an increase in laboratory acoustic measurement of 4 dB at 4 l/s. It should be noted that test data conducted in a controlled laboratory cannot be transferred to other building conditions without restrictions.



Introduction

In drainage installations, safety in case of fire is the primary health and safety concern, both in terms of material properties and reaction in fire, and fire resistance to prevent collapse. The modern, lightweight cast iron of the Harmer SML system offers marked benefits over plastics-based drainage materials and is CE marked.

Superior Performance and Safety in Event of Fire

Harmer SML cast iron pipework is non-combustible and fire safe - cast iron is the ideal material to promote fire safety. In drainage applications, particularly above ground, resistance to fire is the most essential safety requirement - both with regard to reducing risk of damage to the building structure during a fire, and contributing to safety in routes of escape.

The Harmer SML soil and waste system has been extensively tested for the Reaction to Fire under BS 13501-1. This incorporates BS EN 1716 "Heat Combustion", BS EN 13823 "Single Burning Item" and BS EN1182 "Non-combustibility" achieving the following results:

1. Cast Iron material classification A1
2. BS EN 877 states that products must be tested as a complete system to include for pipe connections with elastomer gasket couplings as well as associated fittings and coatings. The highest possible rating was achieved as A2-s1,d0 which is defined as follows:
 - A2 System classification for non-combustible materials
 - s1 Lowest smoke level
 - d0 No flaming droplets

Non-Combustible - Reduced Risk of Flashovers

Because cast iron pipework is non-combustible it does not contribute to deadly flashovers, which can engulf a space with flame in seconds. Flashover is a phenomenon of near-spontaneous ignition, occurring when organic materials are heated and undergo thermal decomposition. This causes a release of flammable gases that lead to simultaneous ignition of combustible materials in any enclosed space. Flashover is a dangerous phenomenon, much feared by fire fighters, who are specially trained to deal with and mitigate the danger from shooting flames during flashovers.

Flashover effect



No Flaming Droplets

In fire, plastic pipework can melt and ignite to form flaming droplets, which can fall from burning material to initiate new fires away from the original point of ignition. Flaming droplets can pass through and spread fire downwards to different parts of a building via plastic pipework, even where fire collars are correctly installed (see diagram below). There is no such risk of fire spread to lower stories when Harmer SML cast iron pipework is installed, and the functionality of a drainage system is maintained throughout a fire if it is cast iron.

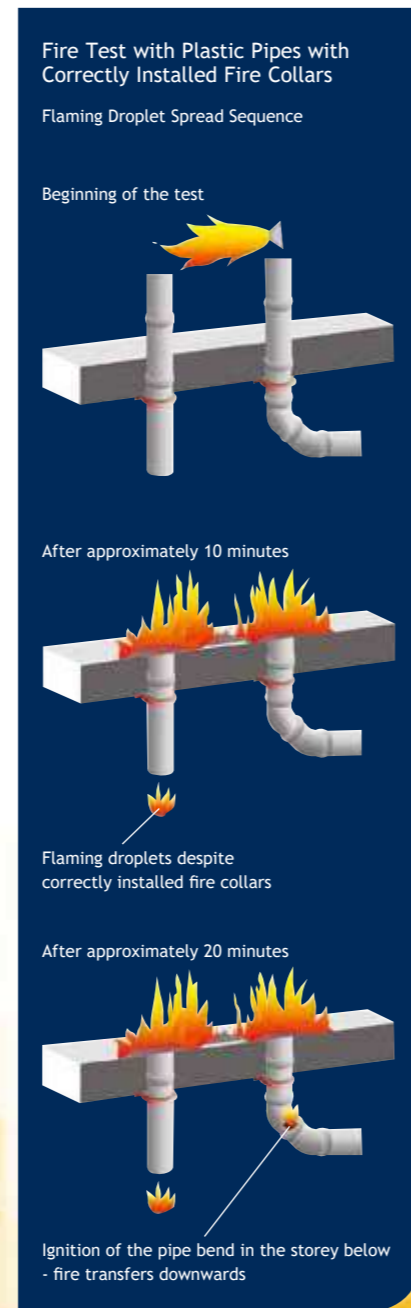

Minimal Smoke Generation

Being non-combustible, cast iron does not burn or generate smoke in the usual sense. Any smoke generated by heat effects on the inner coating of SML pipework is contained within the drainage system and evacuated to the exterior through roof vents.

Minimal Length Expansion

Cast iron has a low coefficient of linear expansion, far lower than that of plastics-based pipework, and any expansion of Harmer SML pipework through heat will be accommodated by the system couplings. With plastics-based pipework, special expansion compensators are required.

Resistance to Fire of Pipe Penetrations

When installed in a building, all water, sewage, heating, gas, ventilation or electric lines will have to penetrate ceilings and walls with a fire resistance requirement. However, penetrations through ceilings and walls are only allowed if the fire resistance of the ceiling or wall is not impaired. Therefore, pipe penetrations must have at least the same fire resistance duration as the ceiling or wall.

Pipe penetrations will be classified for: Integrity (E) Insulation (I)

Testing of the Resistance to Fire of Pipe Penetrations

Throughout Europe, tests for fire resistance of pipe penetrations are based on the test standard EN 1366-3.

Pipes are installed in a furnace, with penetrations through the ceiling and/or the wall of the furnace. With gas or fuel burners, the furnace is heated to a temperature of approximately 1000°C. The standard requires a certain temperature curve and pressure to be maintained.

The test will monitor:

Integrity (E)
by observation. Flames and smoke may not exit through the pipe penetration.

Insulation (I)
by temperature sensors in defined places on the ceiling and the pipe outside the furnace.

The temperature outside may rise by no more than 180°C peak value and no more than 140°C average value.



Some typical fire-proof constructions

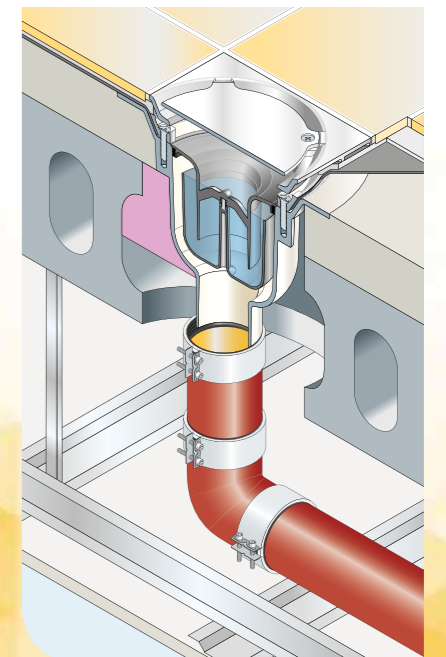
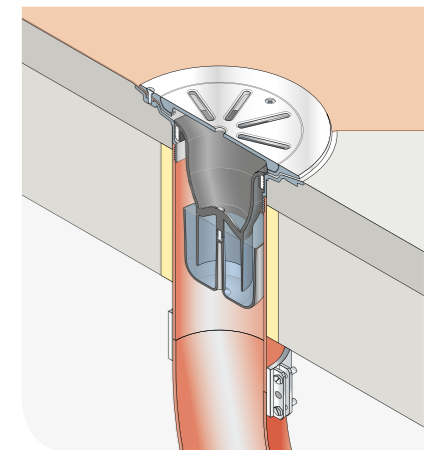
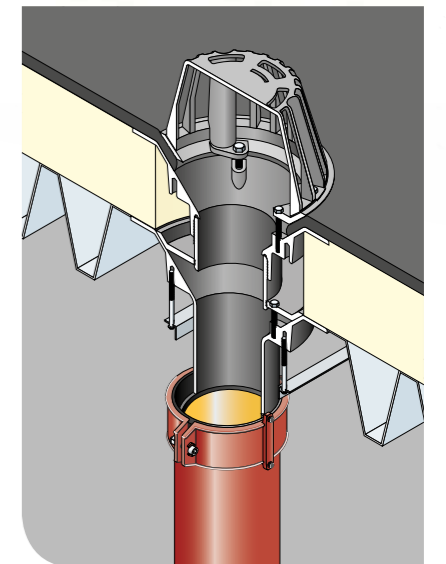

Introduction to Couplings

Harmer SML couplings are available in either ductile iron or stainless steel and meet the requirements of BS EN 877. The internal pressure performance of couplings ranges from 0.5 bar to 10 bar. All couplings feature EPDM elastomeric seals as standard. Neoprene rubber seals are available on request.

The Harmer range of couplings has been put together with the installer in mind. The Harmer Duo and Harmer Grip twin bolt couplings offer quick and easy installation. The couplings are supplied ready to fit onto the pipe, and there is no need to dismantle; simply push fit over the Harmer SML pipe and tighten to the required torque setting. For efficient installation, use the Harmer Duomat Fixing Tool which simultaneously tightens the bolts to the required torque. (See pages 61 and 63 for installation details)

Ductile Iron Couplings

The Harmer SML Ductile couplings are a two-part assembly. Integrated electrical continuity is provided when used for above-ground installations which is activated by tightening two screws located on either side of the coupling (see pages 55 and 60 for further details). Available from 50 to 200mm diameters the couplings are made from Ductile Iron grade EH-GJS-400-15 and coated as RAL 3009 oxide red for above-ground use or RAL 8011 nut brown for below-ground use. The assembly comprises of two sections that are bolted together using M8 bolts incorporating an EPDM gasket.

Stainless Steel Couplings

The Harmer SML Duo coupling is an earth continuous, above-ground, twin-screw stainless steel coupling available for all Harmer SML pipes and fittings, for pipe connections from 50 to 300mm diameter. The Duo continuity coupling can be used (where required by current legislation) to provide earth continuous conductance through the soil stack. When direct contact of all metal components is required, electrical testing of each joint, as work progresses, is recommended.

The Harmer SML Grip coupling is an earth continuous, above-ground, twin screw stainless steel coupling available in 50mm to 200mm diameter. The Grip coupling can be used as an alternative to the Duo coupling where higher internal pressure performances are required. (See table on page 55)

The Harmer SML Adaptor coupling is used when it is necessary to make a connection between BS EN 877 lightweight cast iron 'soil' systems and conventional cast iron thick wall 'drain' systems. This coupling does not incorporate any provision for electrical continuity.

High Pressure Couplings

The Harmer SML Combi Grip Collar EK coupling is a security collar that can be used to provide axial resistance up to 10bar.

The Harmer SML Axilock-S High Pressure coupling is used to provide axial restraint up to 16 bar for pipes installed above ground.

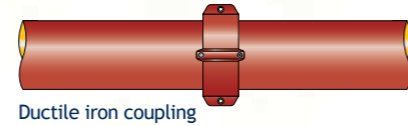

Ductile iron coupling

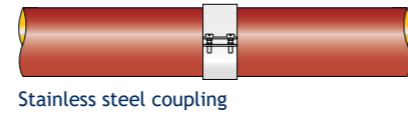

Stainless steel coupling

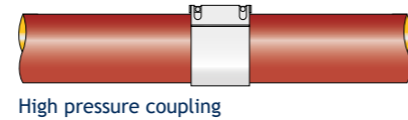

High pressure coupling



Harmer SML Ductile



Harmer SML Duo



Harmer SML Grip



Combi Grip Collar EK



Harmer SML Axilock-S

Couplings Data

Harmer SML Coupling	Material	Type	Dia Range (mm)	Internal Pressure Rating		Torque
				Unrestrained	Restrained*	
Ductile	Ductile iron	Mechanical	50 to 200	0.5 bar	5 bar	22 Nm
Duo	Stainless steel	Mechanical	50 to 300	0.5 bar	50 to 200mm = 5 bar 250 and 300mm = 3 bar	3.5 Nm to 9 Nm
Grip	Stainless steel	Mechanical	50 to 200	50 to 100mm = 3 bar 125mm = 1.5 bar 150 and 200mm = 1 bar	5 bar	7 Nm to 9 Nm
Adaptor	Stainless steel	Mechanical	100 and 150	0.5 bar	5 bar	3.5 Nm to 5.5 Nm
Combi Grip Collar EK	Galvanised steel	Mechanical	50 to 300	50 to 100mm = 10 bar 125 to 150mm = 5 bar 250 to 300mm = 1 bar	50 to 100mm = 10 bar 125 to 150mm = 5 bar 250 to 300mm = 1 bar	25 Nm to 65 Nm
Axilock-S	Stainless steel	Mechanical	50 to 400	50 to 200mm = 16 bar 250 to 400mm = 10 bar	—	As stated on coupling

* Fixed to prevent movement.

Electrical Continuity

The Harmer Ductile, Duo and Grip couplings will satisfy the electrical continuity requirements of the IEE regulations provided that the SML pipework is bonded to an electrical earth and these couplings are assembled, installed and tightened to the correct torque in accordance with our recommendations.

The procedure for testing electrical continuity should be in accordance with the requirements of BS EN 877 as follows:

'If provision is made for electrical continuity, the electrical resistance of the coupling shall not exceed 0.3 ohms, when tested in accordance with the following procedure: Apply a steadily increasing voltage not exceeding 50V ac, 50Hz, across the junction until a steady current of 25±1A flows through the coupling. Allow the current to flow for 30 seconds, maintaining it as necessary by adjusting the voltage. Calculate the resistance of the coupling by dividing the observed voltage by the current.'

The installation should be regularly checked for damage, or when modifications are proposed, to ensure that electrical continuity is maintained.

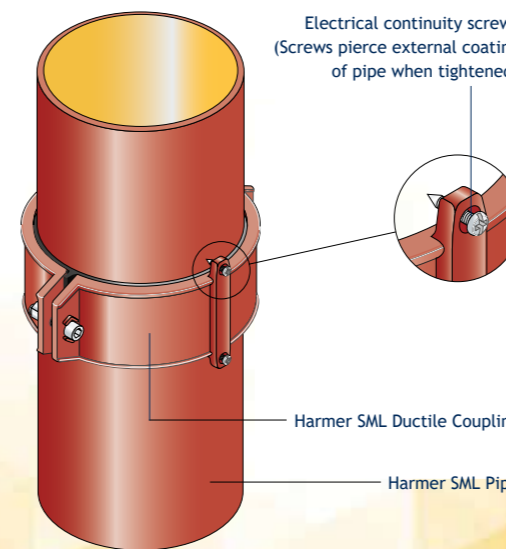

Harmer Ductile Coupling installation

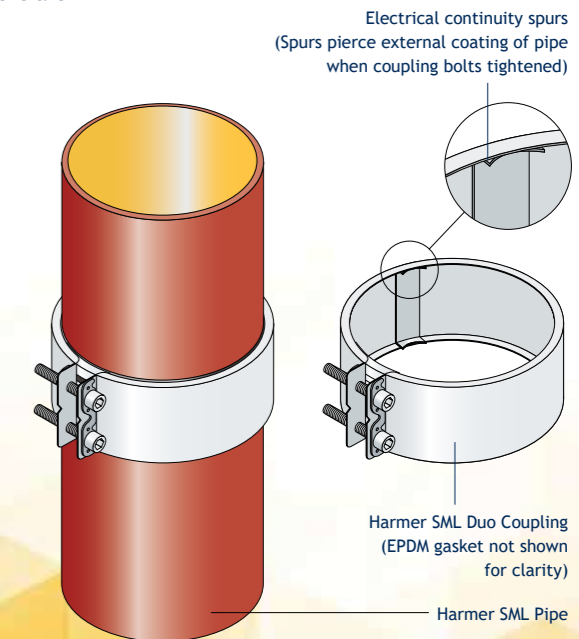

Harmer Duo Coupling installation



Introduction

Harmer SML Brackets are available to support pipework, both vertically and horizontally.

The range comprises vertical and horizontal brackets which are available in either ductile cast iron or zinc plated and fitted with sound deadening rubber linings. Unlined brackets are also available on requested. Please contact Harmer Technical services for details.

Ductile Cast Iron Bracket

The new all-purpose lightweight ductile iron bracket can be used for vertical and horizontal pipework and removes the need for stack supports.

(See page 68 for details)

Features and Benefits

- Elongated slot for fixing, allowing vertical and lateral adjustments
- Lightweight but durable and strong
- Reduce the need for stack supports

Ductile Cast Iron Bracket

Pipe Dia (mm)	Bolt Size ('S' on drwg)	Bolt Head Type	Safe Load (N / kg)*	Application
50	M8 x 30mm	13mm hexagonal head	640N / 64kg	Above ground
70	M8 x 30mm	13mm hexagonal head	990N / 99kg	Above ground
100	M8 x 30mm	13mm hexagonal head	1770N / 177kg	Above & below ground
150	M8 x 40mm	13mm hexagonal head	3230N / 323kg	Above & below ground
200	M8 x 40mm	13mm hexagonal head	5460N / 546kg	Above & below ground

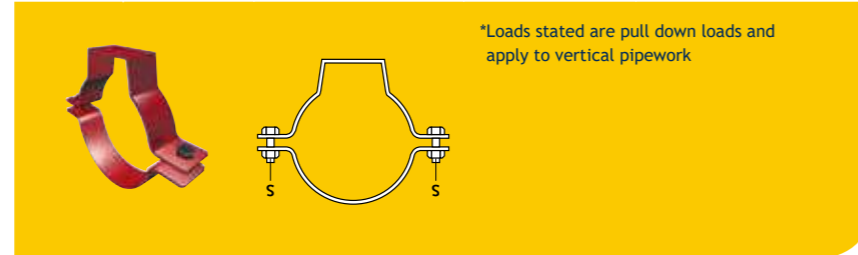

Optimal Bracket

The Harmer Optimal bracket is a general purpose bracket used for vertical and horizontal restraint of pipes up to 200mm diameter. In vertical applications this bracket must be used in conjunction with a vertical support bracket.

(See pages 69 and 70 for details)

Features and Benefits

- Zinc plated
- Anti-vibration ageing-resistant EPDM rubber lining
- Acoustically tested to BS EN 14366: 2004
- Unique latching device (100mm diameter only)
- Hexagonal headed screw with combi-slot
- M8 - M10 dual tapped boss

Optimal Bracket Data

Pipe Dia (mm)	Connecting Boss ('G' on drwg)	Bolt Size ('S' on drwg)	Bolt Head Type	Safe Load (N / kg)*
50	M8 / M10	M6 x 25	10mm hexagonal head with combi slot	1490N / 149kg
70	M8 / M10	M6 x 25	10mm hexagonal head with combi slot	1490N / 149kg
100	M8 / M10	M6 x 25	10mm hexagonal head with combi slot	2170N / 217kg
125	M8 / M10	M6 x 25	10mm hexagonal head with combi slot	2170N / 217kg
150	M10	M6 x 35	13mm hexagonal head with slot	2170N / 217kg
200	M10	M6 x 35	13mm hexagonal head with slot	2170N / 217kg

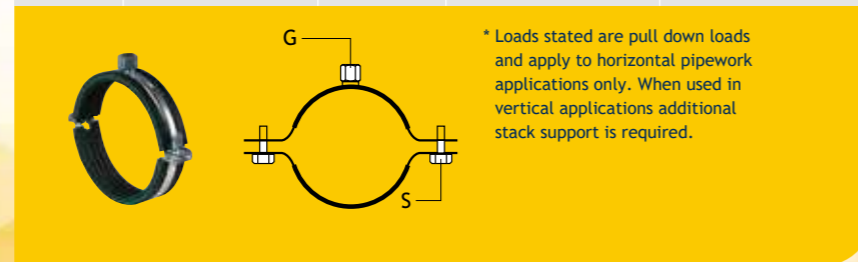

Optimal HD Bracket

The Harmer Optimal HD bracket is a robust bracket suitable for vertical and horizontal restraint of pipes up to 300mm diameter. In vertical applications this bracket must be used in conjunction with a vertical support bracket.

(See pages 69 and 70 for details)

Features and Benefits

- Zinc plated
- Ageing-resistant EPDM rubber lining
- Acoustically tested to BS EN 14366: 2004
- Captive locking nut with anti-loss washer for ease of installation (up to and including 125mm)
- CO₂ welded connection boss
- M10 - M12 dual tapped boss (up to and including 200mm)

Stack Pipe Support Bracket

The Harmer Stack Pipe Support bracket is suitable for supporting vertical pipework up to 200mm diameter. The bracket consists of a cantilever arm and a two-part rubber lined clamp. Harmer Downpipe Support fitting must also be used in conjunction with this bracket.

(See pages 68 and 69 for installation details)

Features and Benefits

- Zinc plated
- CO₂ welded cantilever arm
- Ageing resistant EPDM rubber lining
- Adjustable distance between pipe and wall

Stand Pipe Support Bracket

The Harmer Stand Pipe Support bracket is suitable for supporting vertical pipework up to 150mm diameter. The bracket consists of a two-point wall plate assembly with lateral adjustment and a twin pipe-clamp assembly.

(See page 69 for installation details)

Features and Benefits

- Zinc plated
- CO₂ welded
- Ageing resistant EPDM rubber lining
- Lateral adjustment



Optimal HD Bracket Data

Pipe Dia (mm)	Connecting Boss ('G' on drwg)	Bolt Size ('S' on drwg)	Bolt Head Type	Safe Load (N / kg)*
100	M10 / M12	M8 x 35	13mm hexagonal head	2800N / 280kg
125	M10 / M12	M8 x 35	13mm hexagonal head	2800N / 280kg
150	M10 / M12	M10 x 40	17mm hexagonal head	3900N / 390kg
200	M10 / M12	M12 x 50	19mm hexagonal head	3900N / 390kg
250	M16	M12 x 50	19mm hexagonal head	6500N / 650kg
300	M16	M12 x 50	19mm hexagonal head	6500N / 650kg



Stack Pipe Support Bracket Data

Pipe Dia (mm)	Connecting Nut ('G' on drwg)	Clamp Bolt Size	Bolt Head Type	Safe Load Fy (N / kg)*
70	M8 x 16	M8 x 25	13mm hexagonal head with slot	3000N / 300kg
100	M8 x 16	M8 x 25	13mm hexagonal head with slot	3000N / 300kg
125	M8 x 16	M8 x 25	13mm hexagonal head with slot	3000N / 300kg
150	M8 x 16	M8 x 25	13mm hexagonal head with slot	3000N / 300kg
200	M8 x 16	M8 x 25	13mm hexagonal head with slot	3000N / 300kg

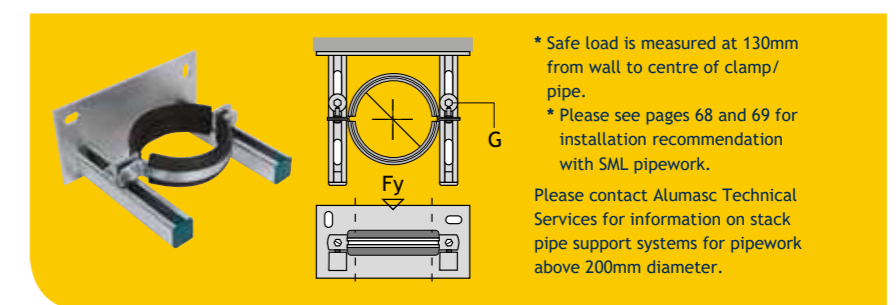

Stand Pipe Support Bracket Data

Pipe Dia (mm)	Connecting Nut ('G' on drwg)	Clamp Bolt Size	Bolt Head Type	Safe Load Fy (N / kg)*
70	M10 with 17mm hexagonal nut	M8 x 25	13mm hexagonal head with combi slot	650N / 65kg
100	M10 with 17mm hexagonal nut	M8 x 25	13mm hexagonal head with combi slot	820N / 82kg
125	M10 with 17mm hexagonal nut	M8 x 25	13mm hexagonal head with combi slot	820N / 82kg
150	M10 with 17mm hexagonal nut	M8 x 25	13mm hexagonal head with combi slot	820N / 82kg

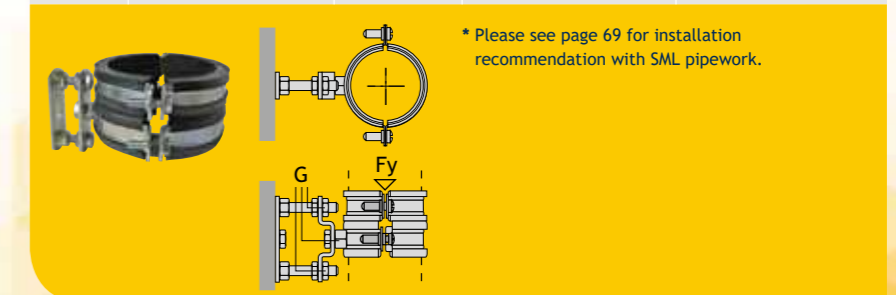



Harmer SML Installation

Installation of the Above and Below Ground drainage system is fast and straightforward, employing positive and secure jointing methods.

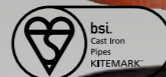

Fixing Tools

Drive Type	Product Code	Description	For Use With
	3900	Harmer Duomat Torque Chuck	Stainless Steel Couplings
	110000	Ratchet Handle 1/2" Drive	For use with 1/2" Drive
	110001	Torque Wrench 1/2" Drive - 20Nm to 40Nm torque range	Couplings with 20Nm to 40Nm torque range
	110007	10mm 1/2" Drive Socket	Harmer Optimal Bracket
	110002	13mm 1/2" Drive Socket	70, 100, 150mm Access Bends, Swept Entry Branches, End Caps, Branch Traps
	110003	18mm 1/2" Drive Socket	150mm Access Pipe Rectangular Door, Branch Trap
1/2" Drive	110004	19mm 1/2" Drive Socket	All pipe sealing flanges
	110008	5mm Allen Key 1/2" Drive Socket	Stainless Steel Couplings
	110005	6mm Allen Key 1/2" Drive Socket	Ductile Iron Couplings, 50mm Axilock-S Coupling
	110013	8mm Allen Key 1/2" Drive Socket	70, 100mm Axilock-S Couplings
	110012	10mm Allen Key 1/2" Drive Socket	125, 150mm Axilock-S Couplings
	110014	14mm Allen Key 1/2" Drive Socket	200, 250, 300, 400mm Axilock-S Couplings
	110006	10mm Flat Bit with 5/16" Hexagonal Shank	General purposes
3/8" Drive	110009	Torque Wrench 3/8" Drive - 4Nm to 20Nm torque range	Couplings with 4Nm to 22Nm torque range
	110010	5mm Allen Key 3/8" Drive Socket	Stainless Steel Couplings
	110011	6mm Allen Key 3/8" Drive Socket	Ductile Iron Couplings

Duomat Fixing Tool

Suitable for all power tools, the Duomat Fixing Tool is recommended for securing Harmer SML couplings. Bolts can be tightened simultaneously with precision. For details of availability please contact Alumasc.



Cutting Pipes

Harmer SML pipe can be readily cut by the use of a powered disc cutter, portable bandsaw, wheel cutter or with chain cutters. Ensure the correct grade of disc appropriate to cast iron is used for disc cutter. Coat cut ends of pipes with appropriate touch-up paint (available on request).

Observe the Health and Safety guidelines from the cutting tool manufacturer's operation manual.





1. Slacken the bolts on the Ductile Iron coupling, fully removing one bolt completely. Remove the EPDM rubber gasket.



2. Push the EPDM rubber gasket over the end of the pipe or fitting, ensuring that the central inner register is abutted against the spigot end.



3. Ease the next pipe or fitting into the EPDM rubber gasket making sure that the spigot end is against the central inner register.



4. Loosely fit the coupling around the gasket, ensuring that the rubber lip sits into the corresponding locator in the coupling. The electrical continuity screws should be drawn back to fullest extent to avoid interference with the connecting pipe or fitting.



5. Check the alignment of the assembly before tightening the bolts. Alternately, tighten the bolts to ensure that the coupling is aligned evenly. Bolts should be tightened until a reasonable resistance is achieved - recommended torque setting 20 Nm.



6. For electrical continuity, hand-tighten the electrical continuity screws on both sides. Ensure screws pierce external coating of pipe when tightened. (See page 55)

All Ductile Iron couplings use an M8 bolt and require a 6mm allen key. The coupling incorporates an anti-turn feature which holds the bolt nut in place without the need for a secondary tool. (See pages 37 and 59 for details of fixing tools)



1. Harmer Duo couplings are supplied factory assembled and ready to fit.



2. Ease-in one side (next to the continuity spur) then push down on the opposite side of the coupling to fully seat, ensuring that the central inner register is abutted against the spigot end.



3. Ease the next pipe or fitting into the coupling as step 2.



4. Evenly tighten the bolts to the required torque setting. The coupling should only be tightened once, because it cannot be dismantled and re-used. (See Couplings Data page 55)



5. The Harmer Duomat fixing tool is recommended for securing Harmer Duo couplings. Bolts can be tightened simultaneously with precision.



Torque wrench, ratchet handle and sockets

A complete range of high quality fixing tools is available from Alumasc. (See pages 37 and 59 for details)

Note:
Harmer Duo, Grip and Adaptor couplings require a 5mm allen key.



Duomat tool



1. Slacken the bolts on the Ductile Iron coupling, fully removing one bolt completely. Remove the EPDM rubber gasket.



2. Push the EPDM rubber gasket over the end of the pipe or fitting, ensuring that the central inner register is abutted against the spigot end.



3. Ease the next pipe or fitting into the EPDM rubber gasket making sure that the spigot end is against the central inner register.



4. Loosely fit the coupling around the gasket, ensuring that the rubber lip sits into the corresponding locator in the coupling.



5. Check the alignment of the assembly before tightening the bolts. Alternately, tighten the bolts to ensure that the coupling is aligned evenly. Bolts should be tightened until a reasonable resistance is achieved - recommended torque setting 22 Nm.



6. All Ductile Iron couplings use an M8 bolt and require a 6mm allen key. The coupling incorporates an anti-turn feature which holds the bolt nut in place without the need for a secondary tool. (See page 47 and 59 for details of fixing tools)



1. Harmer Duo couplings are supplied factory assembled and ready to fit.



2. Ease-in one side (next to the continuity spur) then push on the opposite side of the coupling to fully seat, ensuring that the central inner register is abutted against the spigot end.



3. Ease the next pipe or fitting into the coupling as step 2.



4. Evenly tighten the bolts to the required torque setting. The coupling should only be tightened once, because it cannot be dismantled and re-used. (See Couplings Data page 55)



5. The Harmer Duomat fixing tool is recommended for securing Harmer Duo couplings. Bolts can be tightened simultaneously with precision.



Torque wrench, ratchet handle and sockets

A complete range of high quality fixing tools is available from Alumasc. (See pages 47 and 59 for details)

Note:
Harmer Duo, Grip and Adaptor couplings require a 5mm allen key.



Duomat tool



Harmer SML Application

The Above and Below Ground drainage system provides a flexible response to the requirements of a wide range of modern building applications.

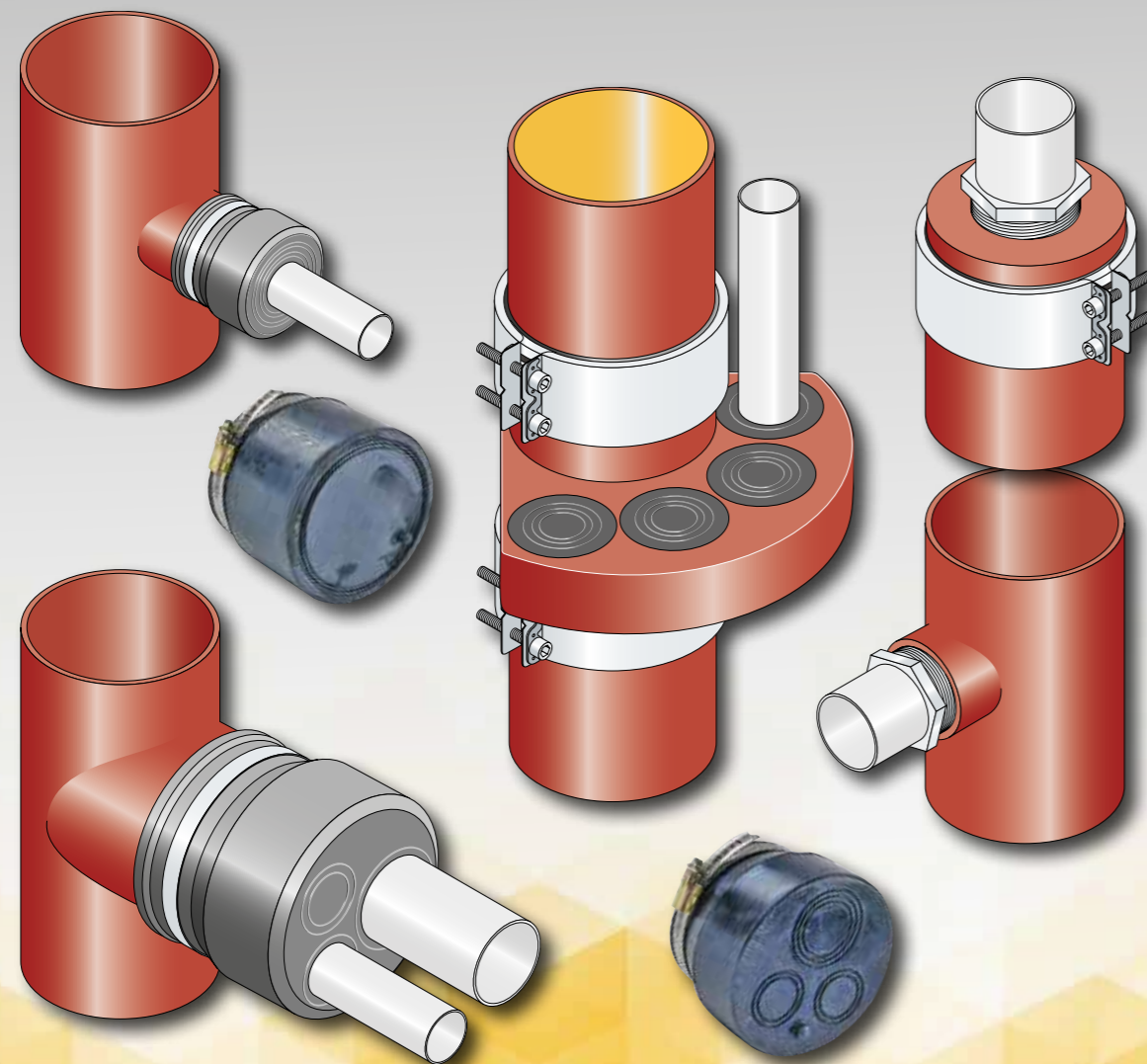

Material Specification

The product standard EN 877, paragraph 4.6.1, details the specification required for the internal and external coating of lightweight cast iron pipes above ground level. Internal coatings for the Harmer SML system have been tested in accordance with 5.7.2 of EN 877 for salt, waste and chemical resistance. External coating is a primary coat that is not readily flammable and is free from toxic metals as per clause 4.6.3 of EN 877.

Harmer SML above-ground pipe is provided with a two-part epoxy coating to the internal surface as an Ochre colour to a minimum thickness of 120 µm. The external surface receives an anti-corrosion primer coating as Red (RAL 3009) to a minimum thickness of 40 µm.

SML fittings are internally and externally coated to the Red specification, dip applied to a thickness of 40µm and therefore complies with the standard.

Pipe connections can be made with either Stainless Steel couplings as in accordance with EN 10088-2 and EN 10088-3 for all grades of austenitic steels or Ductile Iron couplings as defined in table 3, paragraph 4.5.2 of EN 877 stating a minimum tensile strength of 420 MPa and maximum Brinell hardness of 250HB.

Both Stainless Steel and Ductile Iron couplings incorporate Elastomeric EPDM gasket seals as in accordance with BS EN 681-1.

Environmental Conditions

Fire protection should have some consideration for above-ground applications. Although SML has both A1 and the European Class classification A2, the weak area is the building structure in respect of wall and ceiling penetrations. Reference should be made to EN 1366-3.

It is a common occurrence to incorporate plastic waste pipe to a typical SML cast iron system but that constitutes a vulnerable area whereby a non-combustible and combustible material are combined as a mixed system. Adequate protection should be considered.

Although impact sound is relatively low for SML, further acoustic protection may be required depending on the environmental use of the habitable area. The European Standard EN 14366 gives two separate values for airborne sound and structure-borne sound. Airborne sound is measured in the room where the pipeline is installed, structure-borne sound is measured on the other side of the wall to which the pipeline is fixed. When standard brackets are used with rubber inserts, a maximum of 45 dB(A) airborne sound pressure can be created when considering a flow rate of 2 l/s which corresponds to a typical toilet flush. There is a benefit if a pipe bracket with acoustic decoupler is fitted since that would offer structure-borne sound characteristic level of less than 10 dB(A), that is quieter than falling snow!

Pipe Installation

Vertical pipework must be supported with a load bearing bracket to carry the weight of the pipe and its contents. For a 100mm diameter pipe, a stack pipe support bracket is required on every fifth-floor area. In addition, Harmer optimal brackets should be installed at 2m maximum centres or alternatively the Harmer Ductile Iron brackets can be incorporated at 3m maximum centres.

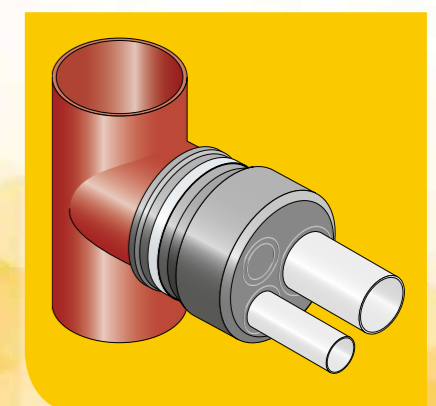
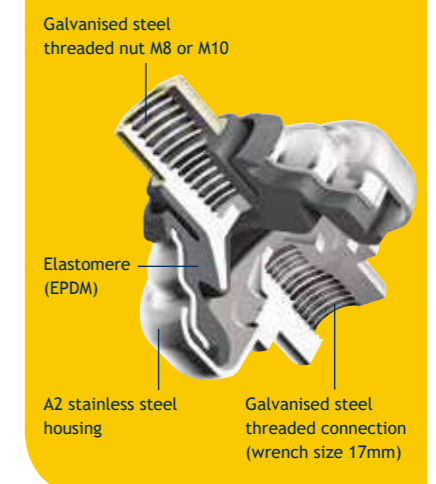



Selection of Material

The product standard EN 877, paragraph 4.8.3.2, contains detailed specifications for the required outside coating on cast iron drainage pipe systems installed underground:

“Pipes shall have an outside coating comprising a layer of metallic zinc covered by a finishing paint compatible with zinc. (...) When measured, the mean mass of zinc per unit area shall not be less than 130 g/m². (...)”

Paragraph 4.8.3.3 says:

“Fittings and accessories shall have a coating (...) of a quality at least equivalent to that of the pipes e.g. (...) epoxy resin based coatings.”

The SML Below Ground System satisfies these requirements.

In paragraph 4.8.4.1, there are specifications for the materials of couplings in underground installation:

“All parts of couplings or clamping components shall be made of cast iron and coated in accordance with 4.8.3.3, or from austenitic stainless steel in accordance with EN 10088-1, EN 10088-2 and EN 10088-3 with at least 16.5% chrome and 8.5% nickel or equivalent, or from material of comparable resistance”.

Should any components be installed that do not correspond to paragraph 4.8 of EN 877, these items must be given on-site corrosion protection, e.g. a bituminous wrapping from the manufacturer Denso.

Soil Conditions

The soil aggressiveness is determined on the basis of many factors, such as soil type, state, water content, pH value, and the level of sulphide, sulphate and chloride present.

The SML Below Ground System is appropriate for the following soil grades as per German DVGW worksheet GW9:

- Ia (practically not aggressive)
- Ib (slightly aggressive)
- II (aggressive)

In case of very aggressive soils (soil grade III), additional corrosion protection such as Denso must be applied to the complete pipeline. The same applies to laying in ground water.

Pipe Bedding

Planning and execution of pipe bedding are to be carried out as per EN 1610 paragraph 7; the German DWA worksheet A139 “Installation and inspection of waste water pipelines and canals”. Corresponding local regulations are also to be recommended.

The thickness of the lower bedding layer of compressible material is at least 100mm; this value should be increased by one tenth of the pipe diameter. In case of very hard soil, the value is at least 150mm and should be increased by one fifth of the pipe diameter.

The thickness of the upper bedding layer is to be determined by the specifier.

For couplings, if necessary, holes should be provided for in the bedding so that the pipeline does not rest on the connections.

Static Calculation

The static calculation follows German DWA work-sheet A127 “Guidelines for the static calculation of waste water pipelines and canals”. Or conform to corresponding local regulations.

Compression of Trench Filling Material

The compression is to be carried out according to EN 1610, paragraph 11 as well as German ATV-DVWK worksheet A139 “Installation and inspection of waste water pipelines and canals”. Or conform to corresponding local regulations.

Bearing Load

The bearing capacity of cast iron drainage pipes can be determined based on EN 877, annex C.2.

Due to its superior material composition, it can be used at variable below-ground depths with typical traffic and surface loadings as common in all site drainage practices.

As a guideline, a simultaneous traffic load of SLW60 for pipe depths of 0.8 to 6m should be assumed.

Leak Test

The water tightness of underground waste water pipelines must be proven as per EN 1610. The test is prescribed after filling the pipe trench; an additional test before filling is however recommended, together with a thorough visual inspection of the pipeline.

The leak test can on principle be carried out with air or with water. Should a test with air fail, a test with water can be done instead. However, we recommend to test with water from the start.

Leak test with air

The leak test with air is to be carried out according to table 3 of EN 1610. The German plumbers’ association ZVSHK recommends the test method LC with a test pressure of 100 mbar, and admissible pressure loss of 15 mbar, and a test duration of 3 to 8 minutes depending on the pipeline diameter.

At first, the pressure is kept up by adding air. This period serves to compensate for temperature differences of the air added. After that, no more air is added and the pressure loss after a defined period of time is measured.

Leak test with water

The test can be carried out on the complete pipeline or on defined pipeline sections.

At first, the length of the pipeline must be determined, in order to calculate the inner surface and the admissible quantity of water to be added.

The test pressure is to be calculated as per the pressure of a water column from the pipe crest of the section to be tested up to the ground level, e.g. 2.5 m = 25 kPa (250 mbar). The test pressure is minimum 10 kPa, maximum 50 kPa.

The pipeline is slowly filled with water from the lowest point so the air contained in it is expelled at the highest point. Upon reaching the test pressure, the pipeline must remain completely filled for one hour in order to compensate for temperature differences.

After one hour, the test period of 30 minutes begins. The pressure is to be kept permanently at the level of the pre-defined test pressure within a tolerance of 1 kPa, by refilling water to compensate for any water leakage. The height of the water column above ground level must not surpass 100 mm in order to prevent increasing the pressure by more than 1 kPa.

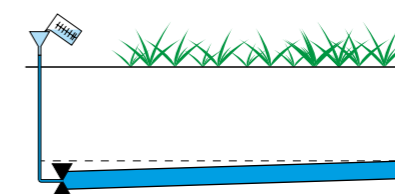

The quantity of refilled water is to be reported. Within the test period it must not be greater than:

- 0.15 l/m² interior surface for pipelines
- 0.20 l/m² for pipelines including shafts
- 0.40 l/m² for shafts and inspection openings

Acceptable Leakage Rates per metre of Pipeline

Pipe Dia (mm)	Inside Surface (m ²)	Max Leakage (l)
80	0.24	0.036
100	0.32	0.048
125	0.40	0.060
150	0.48	0.072
200	0.63	0.095

Securing Against Slipping

As the test is carried out to a maximum of 0.5 bar, we recommend using Ductile Iron couplings which are restrained 3 to 5 bar depending on the pipe size. (See Couplings Data table on page 55 for clarification).

Should higher pressures occur, it is possible to use the Axilock-S coupling or the standard Duo coupling with the Combi Grip Collar. (See table on page 55 for clarification). However, these couplings must either be removed before filling the trench or given additional corrosion protection.

Connections can also be secured with abutments, particularly at changes of direction, such as poles driven into the ground, concrete abutments, cones of filled-on material etc.

Vertical Pipework Support

Vertical pipework must be supported with a load bearing bracket to carry the weight of the pipe and its contents. See page 50 for filled pipe weights. The purpose of these load bearing brackets is to support the stack as it is built up to prevent downward movement of the pipe and unnecessary load at the base of the stack, and to maintain expansion gaps.

It is recommended that Harmer SML is supported either using Ductile Iron Support Brackets (see this page), or Stack Pipe Support Brackets in combination with Optimal Brackets (see page 69). Alternatively, Stand Pipe Brackets (see detail on page 69) or a Rest Bend (shown below) can be used.

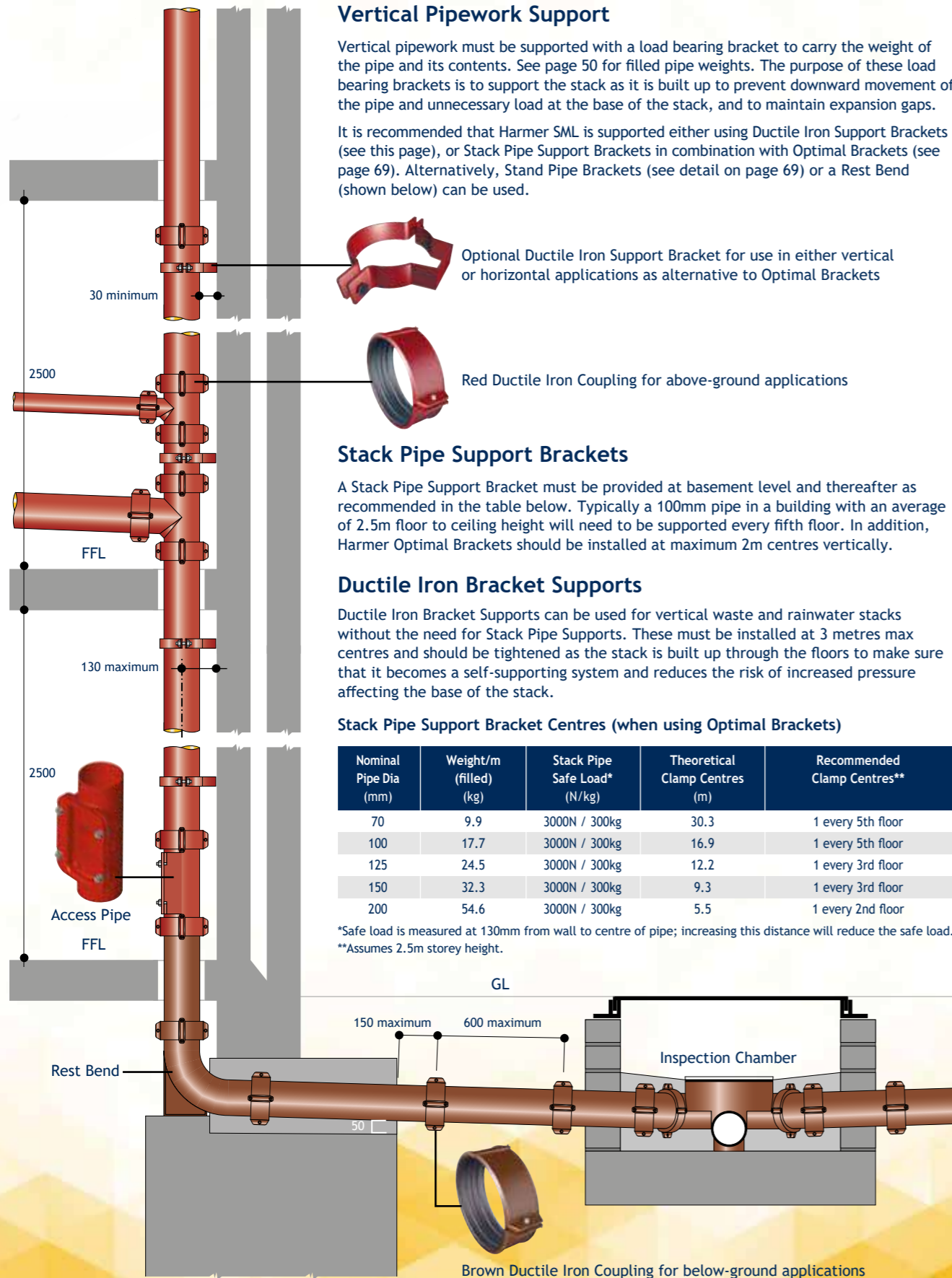

Optional Ductile Iron Support Bracket for use in either vertical or horizontal applications as alternative to Optimal Brackets

Red Ductile Iron Coupling for above-ground applications

Stack Pipe Support Brackets

A Stack Pipe Support Bracket must be provided at basement level and thereafter as recommended in the table below. Typically a 100mm pipe in a building with an average of 2.5m floor to ceiling height will need to be supported every fifth floor. In addition, Harmer Optimal Brackets should be installed at maximum 2m centres vertically.

Ductile Iron Bracket Supports

Ductile Iron Bracket Supports can be used for vertical waste and rainwater stacks without the need for Stack Pipe Supports. These must be installed at 3 metres max centres and should be tightened as the stack is built up through the floors to make sure that it becomes a self-supporting system and reduces the risk of increased pressure affecting the base of the stack.

Stack Pipe Support Bracket Centres (when using Optimal Brackets)

Nominal Pipe Dia (mm)	Weight/m (filled) (kg)	Stack Pipe Safe Load* (N/kg)	Theoretical Clamp Centres (m)	Recommended Clamp Centres**
70	9.9	3000N / 300kg	30.3	1 every 5th floor
100	17.7	3000N / 300kg	16.9	1 every 5th floor
125	24.5	3000N / 300kg	12.2	1 every 3rd floor
150	32.3	3000N / 300kg	9.3	1 every 3rd floor
200	54.6	3000N / 300kg	5.5	1 every 2nd floor

*Safe load is measured at 130mm from wall to centre of pipe; increasing this distance will reduce the safe load.
**Assumes 2.5m storey height.

Stand Pipe Support Brackets

When to use the Stand Pipe Bracket

- When using the Ductile Iron Bracket NO 8
- When using the Optimal Bracket YES 4
- When using the Optimal HD Bracket YES 4



Stand Pipe Support Bracket

The Stand Pipe Support Bracket is an alternative vertical pipe support bracket and can be used where site conditions do not permit the use of the Stack Pipe Support Bracket. The number of Stand Pipe Support Brackets needed varies according to the stack weight. The table below gives details of the maximum distance between each bracket.

Stand Pipe Support Bracket Centres

Nominal Pipe Dia (mm)	Weight/m (filled) (kg)	Stand Pipe Safe Load (N/kg)	Theoretical Clamp Centres (m)	Recommended Clamp Centres*
70	9.9	650N / 65kg	6.6	1 every 2nd floor
100	17.7	820N / 82kg	4.6	1 every 2nd floor
150	32.3	820N / 82kg	2.5	1 every floor

*Assumes 2.5m maximum storey heights.

IMPORTANT

Where Stand Pipe Support Brackets are over 2m centres, additional Harmer Optimal Brackets should be installed to support pipework at maximum 2m centres.

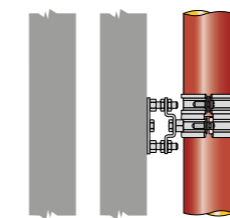

Alternative Stand Pipe Support Bracket



Harmer Optimal Bracket (shown with Wall Plate)



Stack Pipe Support Bracket (shown with SML Downpipe Support)

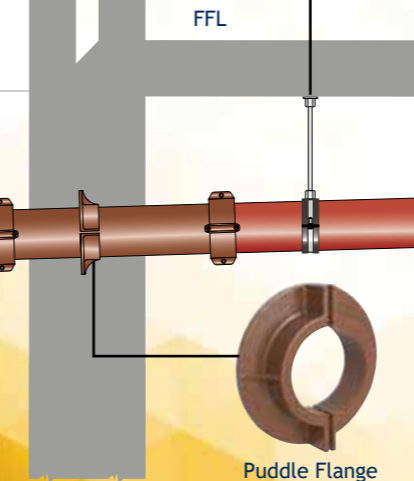

Brown Ductile Iron Coupling for below-ground applications

Puddle Flange

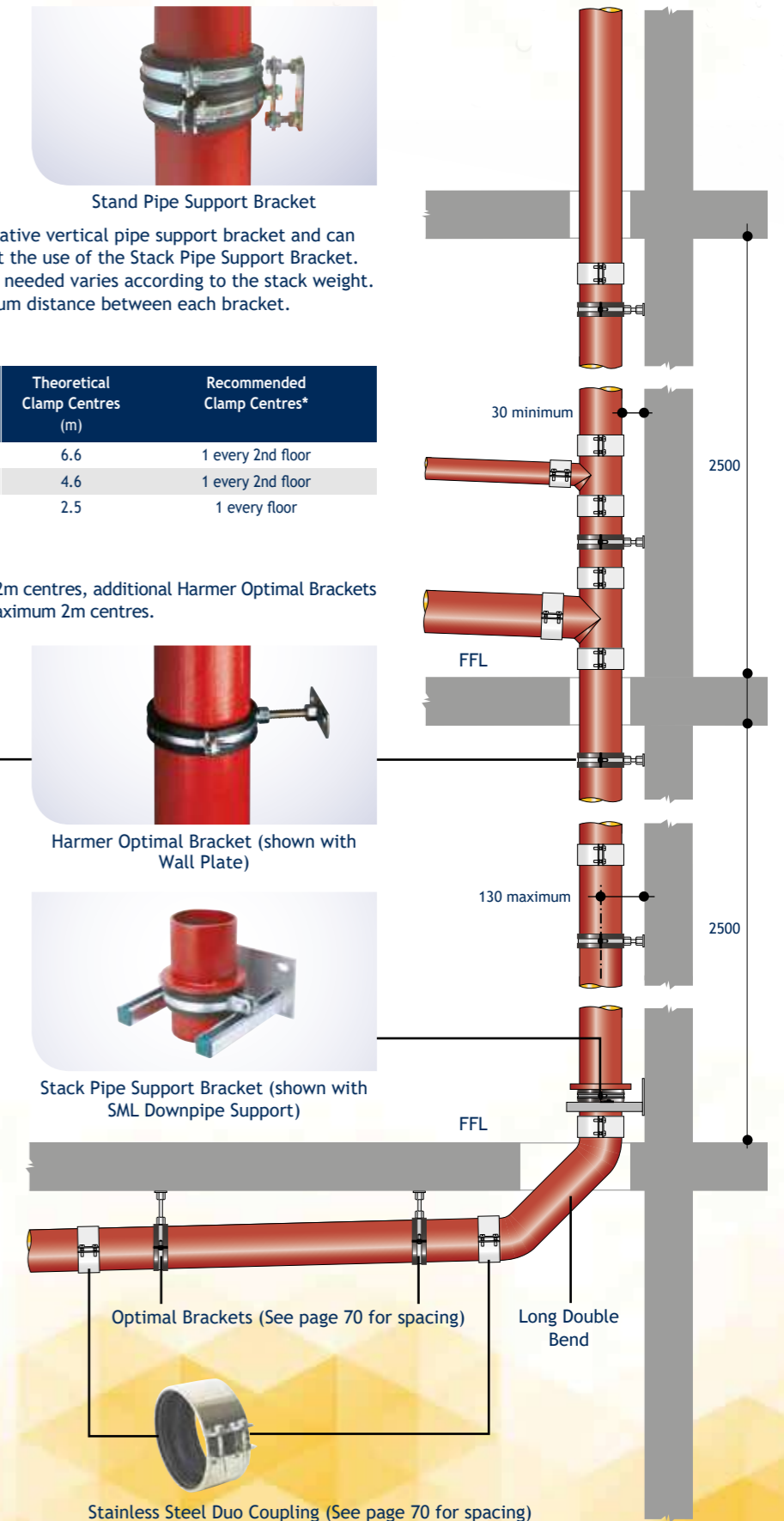

Stainless Steel Duo Coupling (See page 70 for spacing)



Horizontal Pipework Support

Horizontal pipework should be laid to a minimum fall of 20mm per metre, and feeder pipes should be connected to the main pipe using a 45° branch in the direction of the flow. Refer to BS EN 12056-2: Code of Practice for Sanitary Pipework for details.

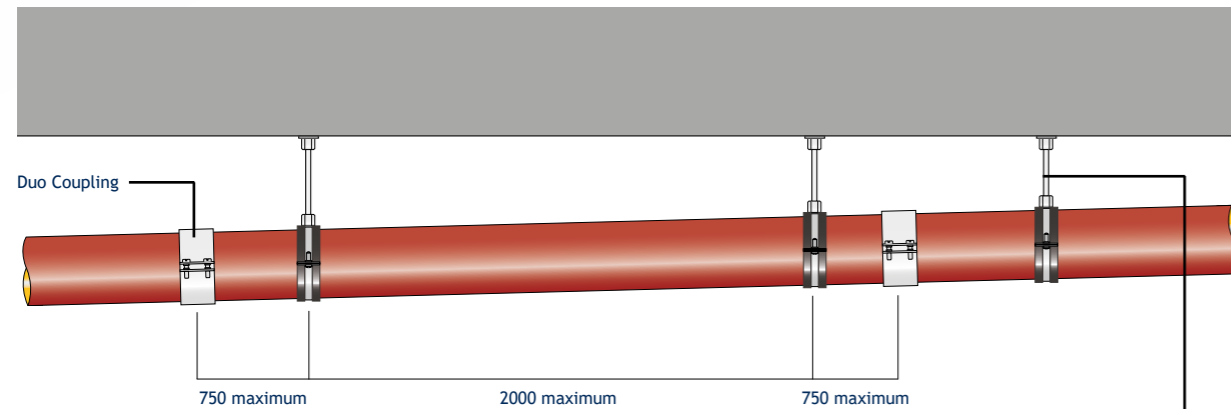

It is recommended that each pipe length in a horizontal pipe run should be supported by 2 brackets, not more than 2m apart. The length of pipe between a bracket and a coupling should not exceed 750mm.

The pipe should be supported at every change in direction or branch. At every 10-15m, a fixing arm should be attached to a bracket to prevent pendular movement of the pipe run. See detail below.



Harmer Optimal Bracket

Harmer SML horizontal bracket and fixing arm

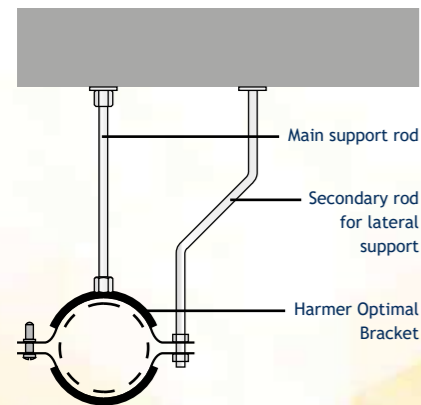

The requirement for pendular restraint may be removed if the pipework has branches entering at 45° or 90° which are supported by at least two hangers.

Alternative arrangement for pipework with drop length over 1 metre

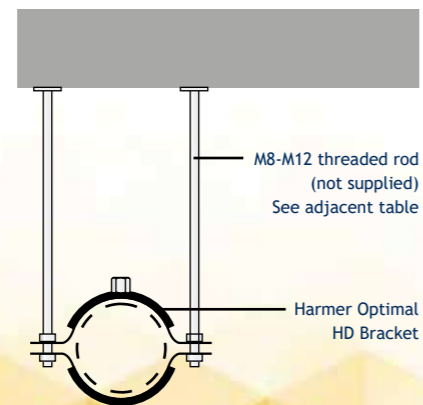

Threaded Rod Data

Optimal HD Bracket (mm)	Threaded Rod Diameter (mm)
100	8
125	8
150	10
200	12
250	12
300	12

See pages 56 and 57 for details of the safe load weights of brackets.

Introduction

The Harmer SML range can be connected to waste pipes using a number of purpose-made connectors as detailed below. It is recommended that a suitable pipe lubricant be used when connecting into a push-fit joint. All connectors are available from stock.

Konfix Single

Suitable for making a single connection from 50-100mm Harmer SML to any drainage material within the size range shown (see table). The Konfix push-fit EPDM adaptor pushes over the receiving pipe and is secured with a stainless steel circlip. The hole for the connecting pipe is created by simply pulling on the pull-out tab which exposes the hole for the connecting material. The connecting pipe must be fixed in order to avoid slippage from internal pressure.

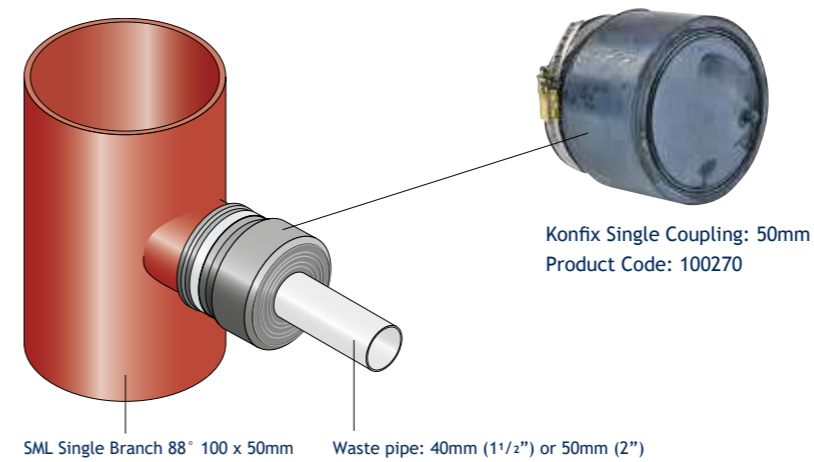

Konfix Single Data

SML Pipe Dia	Connecting Pipe Dia	Insertion Depth	Product Code
50	40-56	42	100270
70	56-75	55	100271
100	104-110	65	100272

All dimensions are in mm.

Konfix Multi

Allows up to 3 connections to Harmer SML 100mm pipework (see table for size range). The Konfix push-fit EPDM adaptor pushes over the receiving pipe and is secured with a stainless steel circlip. The holes for the connecting pipes are created by using a knife to cut into the appropriate groove. The connecting pipes must be fixed in order to avoid slippage from internal pressure.

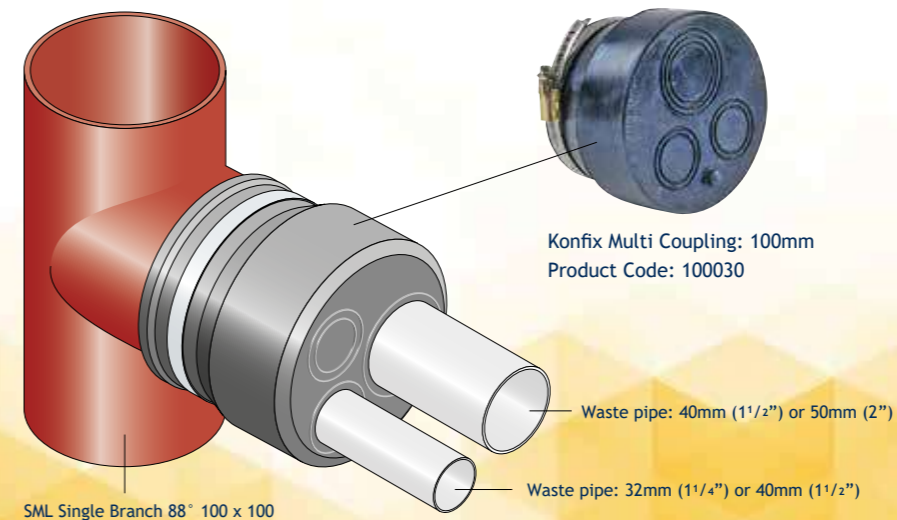

Konfix Multi Data

SML Pipe Dia	Connecting Pipe Dia	Insertion Depth	Product Code
100	2 x 32-40 1 x 40-56	40	100030

All dimensions are in mm.



Tapped End Cap

An end capped, drilled and tapped to 2" BSP, allowing direct connection to a 2" male BSP threaded pipe or to other pipe size using a 2" BSP male iron adaptor (supplied by others).

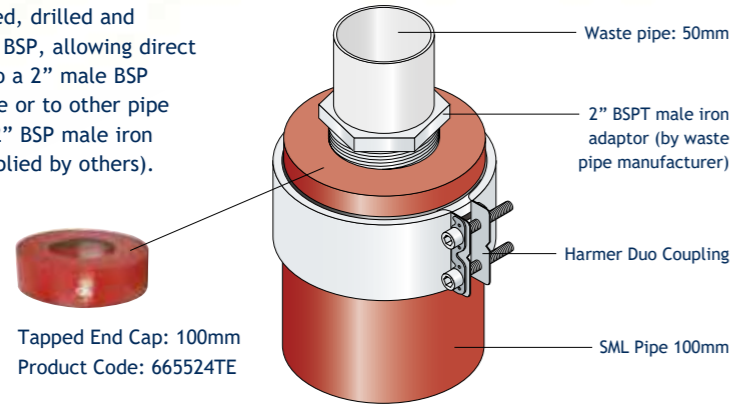

Tapped End Cap: 100mm
Product Code: 665524TE

Tapped End Cap Data

SML Pipe Dia	Product Code
50	665504TE*
70	665514TE
100	665524TE
150	665544TE
200	665554TE

All dimensions are in mm.
*Tap diameter is (1 1/2") BSP

Boss Pipe

Available in 100mm and 150mm dia, boss pipes are drilled and tapped to 2" BSPT. 100mm boss pipes are available in single, double or corner versions. 150mm boss pipe is available with single and double boss. (See page 32 for details)

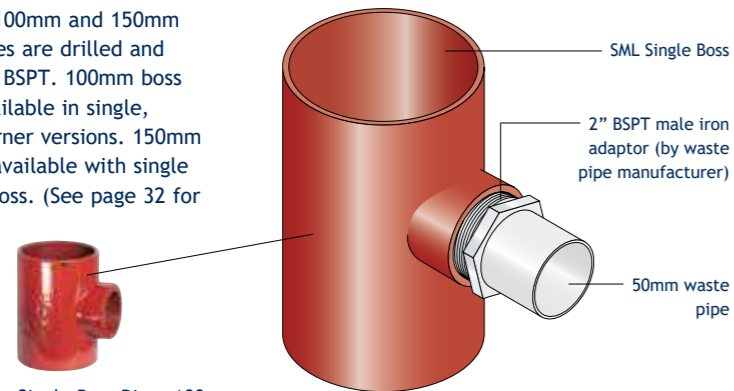

Single Boss Pipe: 100mm
Product Code: 663114B

Boss Pipe Data

SML Pipe Dia	Type	Product Code
100	Single	663114B
100	Double	663114DB
100	Corner	663114CB
150	Single	232746
150	Double	237738

All dimensions are in mm.

Introduction

The Harmer SML Manifold Connector eases waste connection by allowing up to 4 connections into this compact manifold. The Manifold Connector is available in 100mm dia and 150mm dia versions. They are connected directly onto a 100mm dia or 150mm dia Harmer SML pipe stack using any standard couplings. Waste pipework from various sources such as basins, urinals, baths and showers can be conveniently connected to a singular point above the finished floor level.

The Manifold Connector incorporates four rubber grommets in the 100mm dia version and three rubber grommets in the 150mm dia version. Both will permit the connection of 32mm (1 1/4") or 40mm (1 1/2") plastic waste pipes.

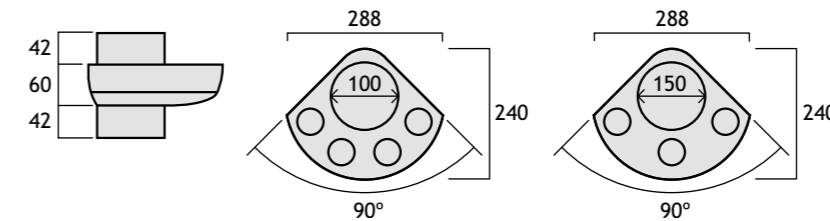

Installation Guidelines

Installation of Manifold Connector

The Manifold Connector body is connected to the stack using standard couplings.

Installation of plastic pipe ends

1. Remove the grommets and pierce the appropriate groove for 32mm (1 1/4") or 40mm (1 1/2") waste connections.
2. Apply appropriate silicon sealant (not provided) to the outside of the grommet and re-fit into the Manifold Connector, making sure that the groove of the grommet is placed correctly in the casing. Ensure sealant is cured before air testing.
3. Lubricate the pipe ends with an appropriate lubricant and insert them into the grommets with a rotational movement. The pipe ends may be chamfered for ease of insertion.

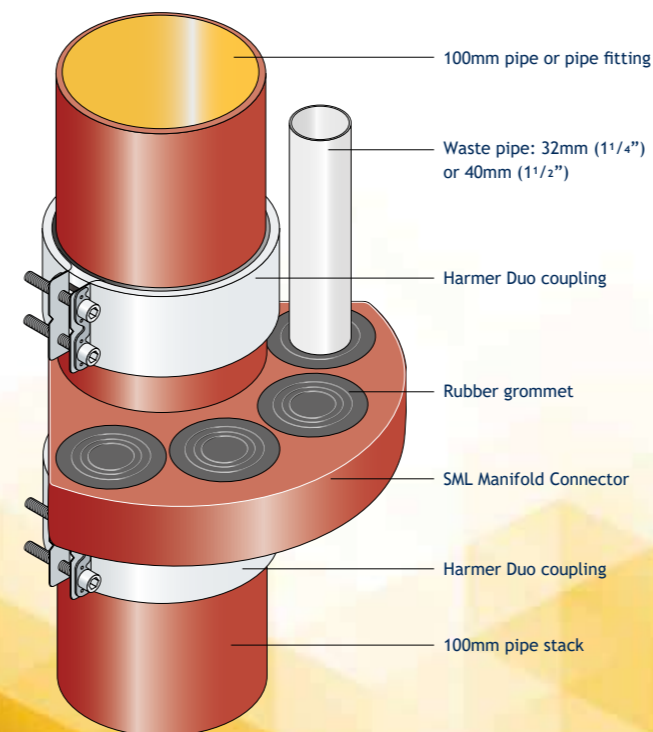

Stoneware Connections

WC Connection

WC connections can be made by using the Harmer SML Stoneware Connector. Alternatively, Harmer SML will accommodate flexible push-fit type connectors.

Clayware

Connect Harmer SML to clayware by using Harmer SML Stoneware Connector with a traditional cement joint.

Traditional Soil

Connect Harmer SML to traditional soil by using Harmer SML Stoneware Connector with a traditional caulked joint.



Stoneware Connector

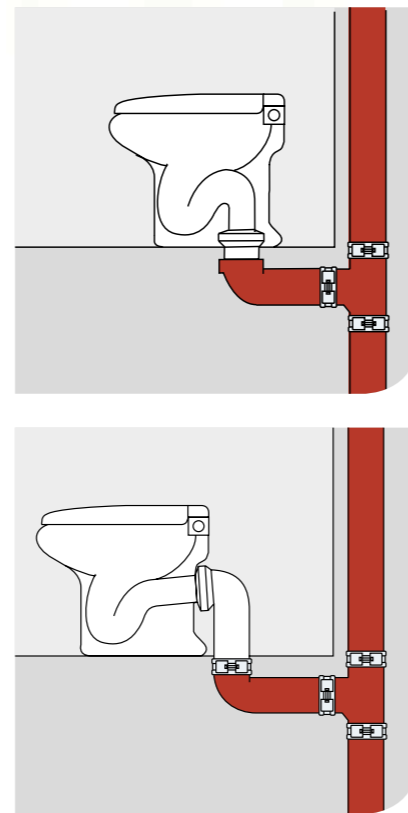

Roof Connections

Projections Through Roof

Where a vent pipe projection occurs through a roof slab with mastic asphalt, the waterproofing must be dressed with a weathering collar to a height at least 150mm above the roof surface.

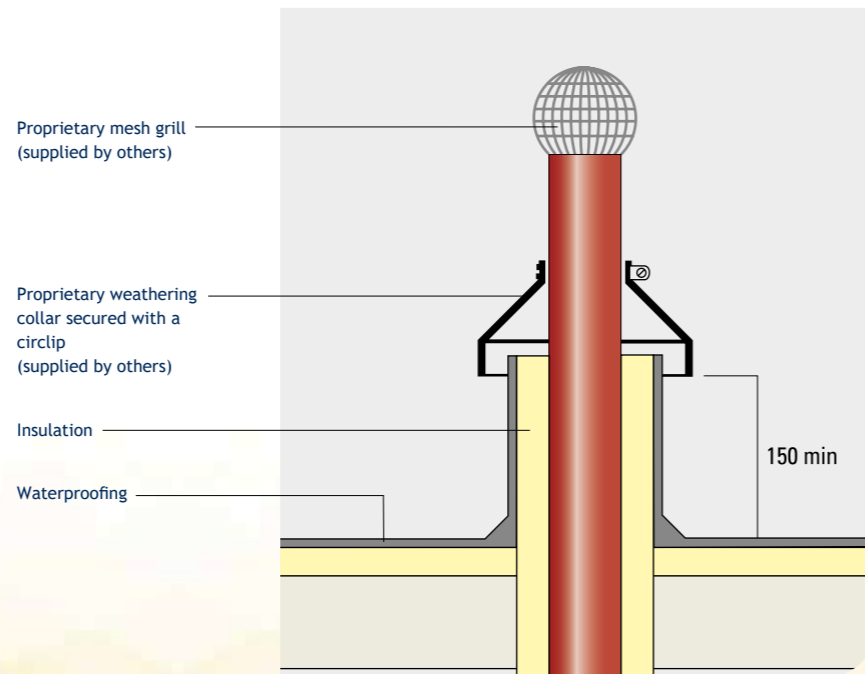

Standard specification guidelines for a 100mm diameter Harmer SML soil and waste system are provided below. NBS format specifications (R11 Above-Ground Foul Drainage Systems) are available for download on the Alumasc website.



Above-Ground Foul Drainage Systems

Inclusive of sanitary and floor drainage outlets; waste pipework; discharge stack and branch pipework; separate ventilating pipework; accessories and disposal.

System Performance

Design to comply with BS EN 12056: 2000, Parts 1, 2 and 5.

Products

Harmer SML Above Ground: Cast iron pipework for internal use.

Manufacturer: Alumasc Water Management Solutions, Burton Latimer, Kettering, NN15 5JP.

Pipes and fittings: To BS EN 877 with flexible joint couplings, Agrément certified.

Accessories: As required.

Size: 100mm diameter.

Method of fixing: Bracket fixed at maximum 2.0m centres when horizontal, but pipe projection beyond each bracket should not exceed 750mm. Pipe should be supported at every change of direction or branch and every 15m a fixing arm should be attached. Horizontal pipeline must be laid to a minimum 20mm per metre fall. Feeder pipes should be connected to the main pipe using a 45° branch connector in the direction of flow. Bracket fixed at 2.0m centres when vertical, supported with a load bearing bracket at every floor adequately supported above and below every branch. Pipes should not be fixed closer than 30mm to a wall. For building of five or more floors plus basement, with an average 2.5m per floor, a downpipe support fitting must be provided at the basement level and every additional fifth floor.

Execution

General installation: To BS EN 12056: 2000, Parts 1, 2 and 5.

Components: From the same manufacturer for each type of pipework.

Electrolytic corrosion: Avoid contact between dissimilar metals where corrosion may occur.

Allowance for thermal and building movement: Provide and maintain clearance as fixing and jointing proceeds.

Concealed or inaccessible surfaces: Decorate before starting work specified in this section.

Protection (purpose made temporary caps): Fit to prevent ingress of debris.

Protection (access covers, cleaning eyes and blanking plates): Fit as the work proceeds.

Pipe Routes

General: The shortest practicable, with as few bends as possible.

Short radius bends in wet portion of soil stacks: Not permitted.

Routes not shown on drawings: Submit proposals before commencing work.

Fixing Pipework

Pipework: Fix securely plumb and/or true to line. Fix discharge stack pipes at or close below socket collar or coupling.

Branches and low gradient sections: Fix with uniform and adequate falls to drain efficiently.

Externally socketed pipes and fittings: Fix with sockets facing upstream.

Additional supports: Provide as necessary to support junctions and changes in direction.

Vertical pipes: Provide a load bearing support not less than every storey level. Tighten fixings as work proceeds so that every storey is self supporting.

Wall and floor penetrations: Isolate pipework from structure, e.g. with pipe sleeves.

Masking plates: Fix at penetrations if visible in the finished work.

Expansion joint sockets: Fix rigidly to the building.

Fixings: Allow the pipe to slide.

Jointing Pipework - Generally

General: Joint with materials, fittings and techniques that will make effective and durable connections.

Jointing differing pipework systems: With adaptors intended for the purpose.

Cut ends of pipes: Clean and square. Remove burrs and swarf.

Jointing or mating surfaces: Clean immediately before assembly.

Junctions: Form with fittings intended for the purpose.

Jointing material: Do not allow it to project into bore of pipes and fittings.

Jointing Pipework

Cast iron, flexible couplings jointing: Paint cut ends of pipes.

Coated Pipes

Cutting: Recoat bare metal.

Electrical Continuity

Joints in metal pipes with flexible couplings: Make with clips (or suitable standard pipe couplings) supplied for earth bonding by pipework manufacturer to ensure electrical continuity.

Identification of Internal Foul Drainage Pipework

Markings: To BS 1710.

Type: Integral lettering on pipe wall, self-adhesive bands or identification clips.

Locations: At 500mm centres, junctions and both sides of slabs, valves, appliances, bulkheads and wall penetrations.

Discharge and Ventilating Stacks

Terminations: Perforated cover or cage that does not restrict airflow.

Material: Stainless Steel, uPVC or HDPE.

Installing Air Admittance Valves

Position: Vertical, above flood level of highest appliance served and clear of insulation materials (other than the manufacturer's insulating cover).

Connection to discharge stack: Allow removal for rodding, e.g. ring seal.

Roof spaces and other unheated locations: Fit manufacturer's insulating cover.

Access for Testing and Maintenance

General: Install pipework with adequate clearance to permit testing, cleaning and maintenance, including painting where necessary.

Access fittings and rodding eyes: Position to avoid obstruction.

Completion and Testing

Dates for testing: Give minimum of 3 days notice.

Pipework preparation: Securely fixed and free from obstruction and debris.

Traps preparation: Filled with clean water.

Testing: Supply clean water, assistance and apparatus. Do not use smoke to trace leaks.

Records: Submit a record of tests.

Pipework Airtightness Test

Open ends of pipework: Temporarily seal using plugs.

Test apparatus: Connect a 'U' tube water gauge and air pump to pipework via a plug or through trap of an appliance.

Testing: Pump air into pipework until gauge registers 38mm.

Required performance: Pressure of 38mm is to be maintained without loss for at least three minutes.

Siphonage and Back Pressure Tests

WC pans: Test by flushing.

Other appliances: Test by filling to overflow level, then removing the plug.

Number of tests: Test each appliance three times. Recharge traps before each test.

Self siphonage testing: Test each appliance individually.

Induced siphonage and back pressure testing: Test by discharging the following numbers of appliances simultaneously on each stack:

- WCs; Washbasins; Sinks: To be confirmed by employers agent.

- Selection of appliances: Submit proposals.

Pre-handover Checks

Temporary caps: Remove.

Permanent blanking caps, access covers, rodding eyes, floor gratings and the like: Secure complete with fixings.



Standard specification guidelines for a 100mm diameter Harmer SML soil and waste system are provided below. NBS format specifications (R12 Below-Ground Foul Drainage Systems) are available for download on the Alumasc website.



Below-Ground Foul Drainage Systems

Inclusive of sanitary and floor drainage outlets; waste pipework; discharge stack and branch pipework; separate ventilating pipework; accessories and disposal.

System Performance

Design to comply with BS EN 12056: 2000, Parts 1, 2 and 5.

Products

Harmer SML Below Ground: For outside of building use only.

Manufacturer: Alumasc Water Management Solutions, Burton Latimer, Kettering, NN15 5JP.

Pipes and fittings: To BS EN 877 with flexible joint couplings, Agrément certified.

Accessories: As required.

Size: 100mm diameter.

Method of fixing: If below ground level such as basements, hanging brackets should be fixed at 2m maximum centres with pipe projection beyond bracket to joint should not exceed 750mm. All horizontal pipe must be laid to the minimum 20mm per metre fall.

Pipe Bedding

Planning and execution of pipe bedding: to be carried out as per EN 1610 paragraph 7; the German DWA worksheet A139 "Installation and inspection of waste water pipelines and canals", or corresponding local regulations are also to be recommended.

The thickness of the lower bedding layer of compressible material to be at least 100mm; this value should be increased by one tenth of the pipe diameter. In case of very hard soil, the value is at least 150mm and should be increased by one fifth of the pipe diameter.

The thickness of the upper bedding layer is to be determined by the specifier.

For couplings, if necessary, holes should be provided for the bedding so the pipeline does not rest on the connections.

Components: From the same manufacturer for each type of pipework.

Electrolytic corrosion: Avoid contact between dissimilar metals where corrosion may occur.

Allowance for thermal and building movement: Provide and maintain clearance as fixing and jointing proceeds.

Concealed or inaccessible surfaces: Decorate before starting work specified in this section.

Protection (purpose made temporary caps): Fit to prevent ingress of debris.

Protection (access covers, cleaning eyes and blanking plates): Fit as the work proceeds.

Pipe Routes

General: The shortest practicable, with as few bends as possible.

Short radius bends in wet portion of soil stacks: Not permitted.

Routes not shown on drawings: Submit proposals before commencing work.

Fixing Pipework

Pipework: Planning and installation of SML Below Ground to follow the technical regulations and stipulations of the following:

EN 12056 Gravity drainage systems inside buildings

EN 752 Drain and sewer systems outside buildings

EN 1610 Construction and testing of drains and sewers

Additional supports: Provide as necessary to support junctions and changes in direction.

Wall and floor penetrations: Isolate pipework from structure, e.g. with pipe sleeves.

Masking plates: Fix at penetrations if visible in the finished work.

Expansion joint sockets: Fix rigidly to the building.

Fixings: Allow the pipe to slide.

Jointing Pipework - Generally

General: Joint with materials, fittings and techniques that will make effective and durable connections.

Jointing differing pipework systems: With adaptors intended for the purpose.

Cut ends of pipes: Clean and square. Remove burrs and swarf.

Jointing or mating surfaces: Clean immediately before assembly.

Junctions: Form with fittings intended for the purpose.

Jointing material: Do not allow it to project into bore of pipes and fittings.

Jointing Pipework

Ductile iron, stainless couplings jointing with EPDM gasket seal as per EN681-1: Paint cut ends of pipes.

Coated Pipes

Cutting: Recoat bare metal.

Electrical Continuity

This is not required for below ground systems due to the earth surrounding properties around a pipe.

Identification of Internal Foul Drainage Pipework

Markings: To BS 1710 and/or EN 877.

Type: Integral lettering on pipe wall, self-adhesive bands or identification clips.

Locations: At 500mm centres, junctions and both sides of slabs, valves, appliances, bulkheads and wall penetrations.

Access for Testing and Maintenance

General: Install pipework with adequate clearance to permit testing, cleaning and maintenance, including painting where necessary.

Access fittings and rodding eyes: Position to avoid obstruction.

Completion and Testing

Dates for testing: Give minimum of 3 days notice.

Pipework preparation: Securely fixed and free from obstruction and debris.

Traps preparation: Filled with clean water.

Testing: Supply clean water, assistance and apparatus. Do not use smoke to trace leaks.

Records: Submit a record of tests.

Leak Test

The water tightness of underground waste water pipelines must be proven as per EN 1610. The test is prescribed after filling the pipe trench; an additional test before filling is however recommendable, together with a thorough visual inspection of the pipeline. The leak test can on principle be carried out with air or with water. Should a test with air fail, a test with water can be done instead. However, we recommend to test with water from the start.

Leak Test with Air

The leak test with air is to be carried out according to table 3 of EN 1610. The German plumber's association ZVSHK recommends the test method LC with at least a pressure of 100mbar, and admissible pressure loss off 15 mbar, and a test duration of 3 to 8 minutes depending on the pipeline diameter. At first, the pressure is kept up by adding air. This period serves to compensate for temperature differences of the air added. After that, no more air is added and the pressure loss after a defined period is measured.

Leak Test with Water

The test pressure is to be calculated as per the pressure of water column from the pipe crest of the section to be tested up to the ground level, eg: 2.5m = 25 kPa (250 mbar). The test pressure is minimum 10 kPa, maximum 50 kPa. The pipe is slowly filled with water from the lowest point, so the air contained in it is expelled at the highest point. Upon reaching the test pressure, the pipeline must remain completely filled for one hour in order to compensate for temperature differences. After that begins the test of 30 minutes. The pressure is kept permanently on the level of the predefined test pressure within a tolerance of 1 kPa, by refilling water to compensate for any water leakage. The height of the water column above ground level must not surpass 100mm in order to prevent increasing the pressure by more than 1 kPa.

In addition to the Harmer SML Above & Below Ground dry-jointed, lightweight cast iron drainage system, Harmer offers other complementary drainage systems, shown below.

For detailed information on these systems, please contact Alumasc Technical Services or visit the Alumasc WMS website: www.alumascwms.co.uk.

Harmer & Wade Roof Drainage



The Harmer & Wade Roof drainage range consists of aluminium, cast iron and insulated polyurethane outlets, and stainless steel and galvanised steel channels. This range of materials and innovative designs provides a comprehensive choice of rainwater outlets and channels that are suitable for all types of roof construction including structural concrete, metal deck, timber deck, warm roof, cold roof, green roof and inverted roof. Harmer & Wade Roof outlets can be used with all types of membrane including asphalt, built-up felt, single ply and wet-applied systems.

Flat and Low-Pitched Roofs

The roof outlet range can be used with all types of flat and low-pitched roofs. Harmer's patented AV aluminium range provides optimum flow performance minimising the number of outlets. The anti-vortex effect accelerates as the depth of water at the outlet, or rainfall intensity, increases ensuring effective water disposal even in extreme weather.

Car Parks, Factories and Workshops

Load bearing applications where rainwater outlets are exposed to vehicular traffic are catered for in both cast iron and aluminium. Ductile iron grates have a load rating up to 12.5 tonnes.

Balconies and Roof Terraces

Adaptable outlet solutions for drainage of balcony areas are available in aluminium, cast iron and stainless steel. In addition, the dedicated Balcony range can be combined with Alumasc architectural rainwater products where colour matching and bespoke manufacture opens up endless design possibilities.

Harmer also provides a comprehensive range of drainage solutions for hard and soft roof landscaping projects. The Harmer Modulock system is an innovative solution for raised deck drainage on green roofs, terraces, walkways and ballasted flat roof construction.

Harmer & Wade Floor and Shower Drains



Drain bodies in cast iron, stainless steel and polyester powder coated aluminium, together with elegant grates, combine to create a range of floor and shower drains to suit virtually any interior drainage application and all types of flooring. Stainless steel linear drainage components add to the range.

Harmer & Wade Floor and Shower Drains show marked advances in design sophistication and performance. With minimum complexity, they are versatile and efficient. Straightforward installation methods mean Harmer Floor and Shower Drains are synonymous with speed and cost effectiveness in any application.

Finely engineered manufacture and enhanced features bring many benefits, including corrosion resistance and durability, with smooth and attractive finishes that are tough and hygienic. Harmer & Wade Floor and Shower Drains are available either trapped or untrapped. The range of grates includes stainless steel and nickel bronze, available in a choice of attractive finishes.





In addition to the SML System, and the compatible Roof Outlets, Floor Outlets and Shower Drains, Alumasc also offers a variety of other quality drainage products, four of which are shown below.

Harmer Backflow Valves

A comprehensive range of single and double flap non-return valves that prevent the back flow of rainwater or waste drainage. Increases in heavy rainfall events have made the occurrence of flooding from storm water drains more common. Harmer backflow valves offer a competitive, proven solution effectively protecting properties from the rising problem of flood water backflow from below-ground drainage systems.



Backflow Valves

Harmer Linearis

The Harmer Linearis shower drainage range removes the need for a conventional shower tray and offers a choice of innovative slimline drainage channels along with more traditional shower gully products, but all with a contemporary styling that will complement any shower or wet room.



Linearis

Harmer Modulock Pedestal

Harmer Modulock is a fully engineered levelling, raised pedestal system for supporting paving slabs, timber or plywood sheet decking at varying heights from the sub-structure.



Modulock Pedestal

Harmer Modulock Channel Drain

Harmer Modulock Channel Drain is a highly versatile linear drainage system designed to provide the ideal level access drainage solution where rainwater run-off and percolation are required.

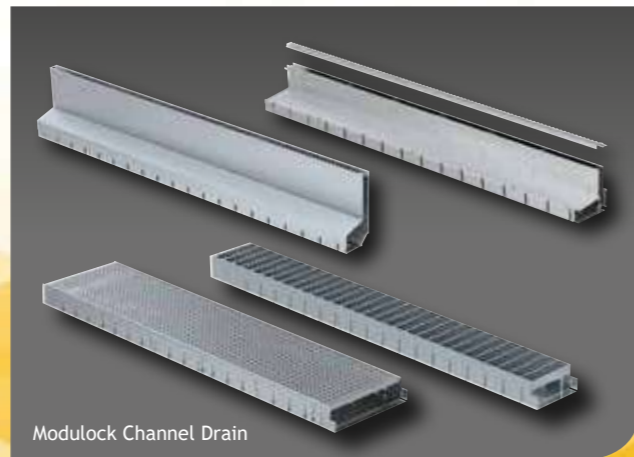

Modulock Channel Drain



Skyline's high performance weatherproofing and integrated guttering systems provide industry-leading rainwater protection.

Skyline includes fascia and soffits, copings, cills and surrounds manufactured from high quality, in-house, BBA certified powder-coated aluminium.



- Fascia
- Soffits
- Copings
- Cills and Surrounds

www.alumascskyline.co.uk



Alumasc is the UK market leader for Aluminium, Cast Iron and Steel gutters and downpipes,

From cutting edge-contemporary to tradition heritage, Alumasc's metal rainwater systems outperform others whatever the weather.



- Aluminium Rainwater Systems
- Cast Iron Rainwater Systems
- Steel Rainwater Systems

www.alumascrainwater.co.uk

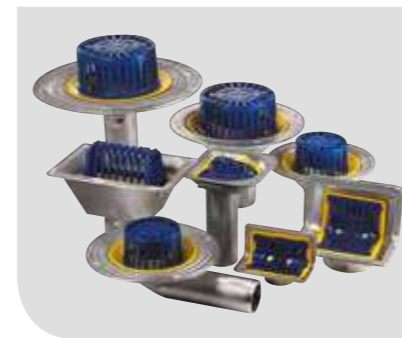

Harmer Building Drainage manages water inside and outside the building.

Its systems allow designers, contractors and clients to realise the design performance and installation benefits of fully integrated drainage solutions.



- Roof Outlets, Floor and Shower Drains
- Cast Iron Soil and Waste Systems
- Paving and Decking Supports

www.harmerdrainage.co.uk



Wade is established as a leading manufacturer of quality drainage products, with more than fifty years' experience in the industry.

It has an on-going commitment to put technology to practical use, to generate fresh ideas, and to guarantee quality assured production.



- Roof Outlets
- Floor Gullies and Access Covers
- Linear Drainage
- Grease Converters

www.wadedrainage.co.uk



Gatic is a global leader in surface water drainage and engineered access covers.

For over 90 years Gatic drainage systems have been used to capture and control surface water drainage. Gatic are the proven international standard for engineered, heavy duty, gas-tight access covers for all types of applications.



- Slotdrain
- Kerb Drainage
- Access Covers

www.gatic.com

HARMER®

BUILDING DRAINAGE

Technical Support

+44 (0)1536 383 810

technical@alumascwms.co.uk

Customer Services

+44 (0)1536 383 810

customerservices@alumascwms.co.uk

AWMS

Station Road

Burton Latimer

Kettering

Northamptonshire

NN15 5JP

+44 (0)1536 383 810

info@alumascwms.co.uk

